



GAS-ALERT MAX

User Manual

Technical Support
Continental North America Toll Free 1-(800) 387-9487
Ph: +1 (905) 829-2418 Fx: +1 (905) 829-4701

A Product of Arjay Engineering Ltd.
Oakville, Ontario, Canada

INTERNET www.ArjayEng.com
www.EnmetGasDetection.com

Toxic Gas Monitor For Ventilation Control

Economical monitoring and control for ventilation of toxic gas in parking garages, warehouses and maintenance facilities

The GasAlert Max monitors up to 20 sensors for a common interlock to fans or alarms. More than 30 years of gas detection experience has contributed to this highly functional monitor.

- central panel offers relays, BAS outputs, and LED alarm status
- up to 20 sensors on one 3-conductor run
- automatic weekly self gas test of CO sensors to ensure safe and continuous monitoring



GasAlert

The GasAlert series is used for direct control interlock to fan contactors or alarms. The central panel monitors a field of up to 20 EC-Gold sensors. This unit is ideal where simple discrete alarm control is desired within a defined zone.

EC-Gold sensors are used in the facility for reliable and accurate monitoring of the target gas. The carbon monoxide sensors have the unique capability to generate a gas test daily to verify the sensor response.

■ Features and Benefits

- LED alarm status indication at main panel and at each sensor
- high, low, and fault relay outputs for control interface
- adjustable time delay on AND off for all relays
- wall mount heavy duty metal enclosure
- buzzer with silence button available
- 3 year sensor life guarantee, 5 year expected life (CO sensor)
- weekly self gas test verifies sensor is active (CO sensor)
- electrochemical sensors minimize interference gases
- easy sensor mounting with external calibration and test features

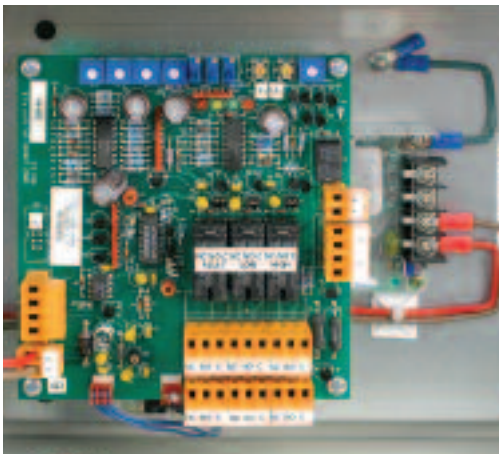

Convenient relay connections and user set-up are at the main control unit.

■ Technical Specifications - Control Unit

Operating Temperature	-20°C to 50°C, indoor use
Power Input	24 vdc, 110 vac or 220 vac
Standards	UL, CSA
Enclosure	Nema/Type 1

■ Technical Specifications - Sensor

Operating Temperature	-20°C to 40°C, indoor use
Power input	24vdc, 0.1 amp each
Mounting	surface mount, rear or top conduit

Standard Sensor gases available:
Carbon Monoxide, Hydrogen Sulfide, Chlorine, Ammonia, Nitrogen Dioxide, Broad Range Toxic, Combustibles and Refrigerants.
Ask about our specialty gases.



The EC-Gold offers easy plug-in wiring connects and a unique long life sensor.



<u>MODEL</u> GAS-ALERT MAX	<u>DOCUMENT TYPE</u> USER MANUAL	<u>DOCUMENT FILE NAME</u> MgsImx23.doc	<u>REV.</u> 2.3
<u>CREATE DATE</u> 08/25/97	<u>REV. DATE</u> 10/24/2006	<u>PRINT DATE</u> 10/24/2006	

TABLE OF CONTENTS

1.0	THEORY OF OPERATION	3
2.0	UNPACKING	3
3.0	SENSOR LOCATION	3
4.0	INSTRUMENT OVERVIEW	4
4.1	FEATURES	4
4.2	DESCRIPTION	4
4.3	SPECIFICATIONS	4
5.0	INSTALLATION	5
5.1	MECHANICAL INSTALLATION	5
5.2	ELECTRICAL HOOKUP	5
5.2.1	POWER	5
5.2.2	REMOTE SENSOR	5
5.2.3	RELAYS	5
5.2.4	BUILDING AUTOMATION SYSTEM (BAS) CONNECTION	6
5.2.5	AUDIBLE ALARM (Optional)	6
6.0	CALIBRATION AND SETUP	6
6.1	CALIBRATION OF INTEGRAL MOS SENSOR	6
6.2.1	CALIBRATING THE INTEGRAL SENSOR	6
6.2.2	SETTING THE TIME DELAY RELAYS	7
6.2.3	COMPLETION	8

<u>MODEL</u> GAS-ALERT MAX	<u>DOCUMENT TYPE</u> USER MANUAL	<u>DOCUMENT FILE NAME</u> Mgslmx23.doc	<u>REV.</u> 2.3
<u>CREATE DATE</u> 08/25/97	<u>REV. DATE</u> 10/24/2006	<u>PRINT DATE</u> 10/24/2006	

1.0 THEORY OF OPERATION

The Gas-Alert Max is a single zone monitor with two alarm points which employs Metallic Oxide Semiconductor (RLU MOS Series) sensing elements and/or Electrochemical sensors (EC-Gold Series). In the presence of a gas, a voltage output is produced. Depending on the specified gas level, this output enables the activation of alarms, relays, etc. at desired levels. The MOS technology is also referred to as Broad Range sensing because the sensor will respond to a *broad range* of gases. The Electrochemical sensors (EC-Gold Series) may be referred to “wet chem” or “near specific”.

The sensor selected for this unit has been determined to be the most suitable for your target gas. The unit and sensor have been calibrated to specific alarm levels using the target gas for this application (i.e. carbon monoxide).

Other toxic or combustible gases may also cause the sensor to respond and alarm the unit. The sensors should be installed in areas where influencing background gases are not constantly present.

Your Enmet gas detector is the state of the art in gas detection, but like any other part of your ventilation system, it requires periodic maintenance and calibration.

The MOS sensors and the Carbon Monoxide (EC-Gold) used in your new gas detector will have a normal operating life of 3 to 5 years under ambient conditions. The other EC-Gold Series sensors will last about 1-2 years. You should consider a preventive maintenance schedule whereby you test your system on a periodic basis to ensure its proper calibration and operation.

Most users have their unit tested every three to four months with test gas. This is a simple procedure, which will indicate any problems with your system. A sensor fault is indicated for the MOS and Carbon Monoxide (EC-Gold Series) sensor only. Other electrochemical sensors are not acknowledged when their operating life has expired.

A test and calibration kit may be purchased from Enmet for this purpose. Parts are also readily available from our facility.

2.0 UNPACKING

Inspect all parts of the gas detector upon receipt for any damages that may have occurred during shipping and that all parts ordered were received. Contact Enmet Canada or your local representative if anything is in error or damage is suspected.

3.0 SENSOR LOCATION

Gases of different molecular structures have different densities; some are heavier than air and concentrate at the bottom of a space and some will rise.

The following is a general guide. For assistance in sensor location consult your Enmet Representative.

Carbon Monoxide	same as air	place about 4-6' above finished floor *
Methane	lighter than air	place near ceiling
Ammonia	lighter than air	place near ceiling
Propane	heavier than air	place about 2' above finished floor
H ₂ S	heavier than air	place about 2' above finished floor
Freon	heavier than air	place about 2' above finished floor

* Check Local building codes. (i.e. Ontario Building code requires mounting at 2'11" to 3'11")

NOTE: Place sensors in a location that is easily accessible for calibration and testing. Mount so the sensors are

<u>HARDWARE REV.</u> 1.0	<u>SOFTWARE REV.</u> N/A	Page 3 of 8
-----------------------------	-----------------------------	-------------

MODEL GAS-ALERT MAX	DOCUMENT TYPE USER MANUAL	DOCUMENT FILE NAME Mgslmx23.doc	REV. 2.3
CREATE DATE 08/25/97	REV. DATE 10/24/2006	PRINT DATE 10/24/2006	

facing downward to avoid dust or debris collection on the sensor.

4.0 INSTRUMENT OVERVIEW

4.1 FEATURES

- Supports one integral MOS sensor and up to 8 Enmet Remote MOS Sensors or 9 Enmet Remote MOS Sensors or 20 Remote EC-Gold Series Sensors.
- DPDT 250 VAC / 5A relay contacts for High, Low and Sensor Fault alarms
- Adjustable / independent 0-20 minute time delay to on and delay to off for High and Low alarms
- Independent Fail-Safe setting for High and Low alarms
- Board level Audible alarm output with silencer. Remote audible alarm & silencer push-button optional
- Adjustable time delay for Audible Alarm (delay starts after High alarm)
- Board level Push to Test button. Remote Push to Test push-button optional.
- Additional High and Low alarm outputs (+24V out) to Building Automation System (BAS)

4.2 DESCRIPTION

The Enmet Gas-Alert Max detection systems offer the ability to monitor for a variety of gases. It offers DPDT contacts for High, Low and Sensor Fault alarms. In addition, High and Low signals are also available for connection to a Building Management System (BMS). High and Low alarms have independent Delay-ON and Delay-Off time delays adjustable from 0 – 20 minutes (total of 4 delay adjustments).

4.3 SPECIFICATIONS

FUNCTION

Two level alarm system: High and Low Alarms plus Sensor Fault Alarm

SENSOR TYPE

MOS (Metal Oxide Semiconductor) or Electrochemical Sensor (EC-Gold)

GASES

CO, Propane, CH₄, NH₃, H₂S, Cl₂, NO₂ (consult factory for others)

ALARM RELAYS

Relays	3 DPDT relays for High, Low and Sensor Fault Alarms
Contacts	250 VAC or 30 VDC @ 5A
Fail-Safe	Fail-Safe / non-fail-safe settings for all 3 relays
Time Delay	0 – 20 minutes. Independent Delay-On and Delay-Off for both High and Low Alarm relays (total 4 delay adjustments)

BAS OUTPUTS

Signal output	High and Low Alarm status outputs. +24V when alarm is active, 0V if not. The status signals reflect the alarm condition AFTER the corresponding alarm delays i.e. the status signal is active while the corresponding alarm light is active.
Drive capability	The status signals are meant to be connected to a BAS / PLC and are not intended to drive any appreciable load. A 330 Ohm resistor protects each output. Thus for a 500 Ohm load, the output voltage is 14.5V, and for a 1000 Ohm load the output voltage is 18.0V.

AUDIBLE ALARM (Optional)

Function	Activated on High Alarm. (After High Alarm Delay)
Drive capability	24V @ 50 mA max. If greater drive is required, use a slave relay.
Silencer	Push-button silencer (auto-reset). Connection for remote silencer push-button (optional)
Time Delay	0 – 20 minutes Delay – On. (In addition to High Alarm Delay-On).

HARDWARE REV. 1.0	SOFTWARE REV. N/A	Page 4 of 8
-----------------------------	-----------------------------	-------------

MODEL GAS-ALERT MAX	DOCUMENT TYPE USER MANUAL	DOCUMENT FILE NAME Mgslmx23.doc	REV. 2.3
CREATE DATE 08/25/97	REV. DATE 10/24/2006	PRINT DATE 10/24/2006	

DIAGNOSTICS

Push to Test push-button. Tests by forcing a Sensor Fault on the internal sensor. Alarm lights, relays, and BAS status signals are tested. Note: the time delay settings are still active during test. Adjust them to 0 minutes prior to test if the time delays are not to be tested.

POWER

Internal sensor only 115 VAC @ 1.4 A, when supplied with a power supply (220 VAC available)
24 VDC @ 0.5A max. (Standard).
Remote Sensor System 24 VDC @ 0.5A + 0.25A per Remote MOS Sensor /100mA per Electrochemical (EC-Gold Sensor)

MECHANICAL SPECIFICATIONS

Enclosure Nema 4X, Epoxy Coated Steel
Dimensions 8" X 8" X 5"
Weight 6.5 lb.

ENVIRONMENTAL SPECIFICATIONS

Operating Temp. -20 to 60 Deg. C
Relative Humidity 90% max. with no condensation.

5.0 INSTALLATION

5.1 MECHANICAL INSTALLATION

See Drawing 972307

5.2 ELECTRICAL HOOKUP

See drawing 972300

5.2.1 POWER

The standard power input is 24 VDC. If this is being used then locate the power supply connector at the bottom left of the Gas-Alert Max board and connect the 24 VDC as shown on drawing 972300. The connector is a 2-conductor mating pair arrangement. The connector may be unplugged for ease of wiring.

If 115 or 220 VAC power is to be used then locate the separate VAC input power supply and connect the Line, Neutral and GND connections as labeled on the back panel.

5.2.2 REMOTE SENSOR

The Gas-Alert Max may have one integral MOS sensor and remote MOS/EC Gold sensors. The remote MOS sensor is connected via a 4-conductor 16-18 gauge shielded wire, cable that carries power (2 conductors) and a common remote signal pair. The Electrochemical (EC-Gold Series) is connected via a 3 conductor 16-18 gauge shielded wire. See dwg 20010201 for more details.

Locate the Remote Sensor connector on the left edge of the Gas-Alert Max board.

5.2.3 RELAYS

Three DPDT 250 VAC / 5A contact relays are provided: for High Alarm, Low Alarm, and Sensor Fault. These relays are common to the integral sensor and the remote sensors, i.e. if the integral sensor or the remote sensor is in low alarm then the Low Alarm relay and LED are activated.

Sensor Fault: If any MOS sensor (integral or remote) or the Carbon Monoxide (EC-Gold Series) is removed then the Sensor Fault relay and LED are activated.

NOTE: Each relay may be set as Fail-Safe (normally energized, and de-energized on alarm condition) or

HARDWARE REV. 1.0	SOFTWARE REV. N/A	Page 5 of 8
-----------------------------	-----------------------------	-------------

MODEL GAS-ALERT MAX	DOCUMENT TYPE USER MANUAL	DOCUMENT FILE NAME Mgslmx23.doc	REV. 2.3
CREATE DATE 08/25/97	REV. DATE 10/24/2006	PRINT DATE 10/24/2006	

non-fail-safe (normally de-energized, and energized on alarm condition).

The connections are as shown on drawing 972300.

5.2.4 BUILDING AUTOMATION SYSTEM (BAS) CONNECTION

The Gas-Alert Max provides external High and Low Alarm status signals (+24V when in alarm, 0 V when not) for connection to a Building Automation System (BAS). The signals are non-isolated and are referenced to the provided +24V power supply ground.

The connection is located on the right edge of the Gas-Alert Max board as shown on drawing 972300.

5.2.5 AUDIBLE ALARM (Optional)

The Audible Alarm connector (2 conductor) is located on the right edge of the Gas-Alert Max board. The connection is either to a Horn / Buzzer on the side panel (typical) OR connected to a remote horn / buzzer (both optional). The output is +24V @ 50 mA (maximum current). Some horns / buzzers are polarity sensitive i.e. make sure the + output is connected to the + terminal of the horn.

6.0 CALIBRATION AND SETUP

6.1 CALIBRATION OF INTEGRAL MOS SENSOR

The Gas-Alert Max may have up to 9 MOS sensors (all remote or one integral and the rest remote) or up to 20 Electrochemical (EC-GOLD Series) sensors. **The integral sensor may be only of the MOS technology.** See the following calibration procedures for the integral sensor. If other sensors are supplied, please find the additional sensor manual(s) required at the end of this manual.

6.2.1 CALIBRATING THE INTEGRAL SENSOR

NOTE: If an integral sensor is not being used a resistor is factory jumpered across the input terminal block (J9). Verify this is in place and proceed to 6.2.2

Calibrating the integral sensor requires:

- Enmet Calibration Kit which should have calibration gas concentrations for the required High and Low alarm values.
 - Small slot screwdriver to adjust the alarm levels.
 - The Gas-Alert Max should be powered up for 48 hours prior to calibration to allow the sensor to stabilize.
 - A Voltmeter.
1. Locate Test Point 1 (named TP1: Black) (See drawing 972300). It is located at the bottom left of the Gas-Alert Max board. Locate Test Point 2 (named TP2: Red). It is located roughly an inch above TP1. Plug the negative lead of the voltmeter into TP1 and the positive lead to TP2. The measured voltage will be in the 1.5 – 5 Volt range.
 2. Locate the Range potentiometer (labeled N) on the top edge of the Gas-Alert Max board. With the small adjusting screw, adjust the pot. to get approx. 2.8 VDC (+/- .2) volts on the voltmeter in clean air.
 3. Prior to calibration, adjust all 4 time delay pots to 0: fully counter clockwise. The delay adjust pots are in a group of 4 located on the top left edge of the Gas-Alert Max board.
 4. **SETTING THE LOW ALARM:** Setup the Enmet calibration kit as per the Enmet calibration kit drawing (see fig 1.0). You will need a gas canister containing the gas concentration of the low alarm level (i.e. if the low alarm is to be set at 35 PPM Carbon Monoxide then the canister should contain 35

HARDWARE REV. 1.0	SOFTWARE REV. N/A	Page 6 of 8
-----------------------------	-----------------------------	-------------

MODEL GAS-ALERT MAX	DOCUMENT TYPE USER MANUAL	DOCUMENT FILE NAME Mgslmx23.doc	REV. 2.3
CREATE DATE 08/25/97	REV. DATE 10/24/2006	PRINT DATE 10/24/2006	

PPM Carbon Monoxide). Attach the calibration cup over the Gas-Alert Max integral sensor and adjust the gas flowrate to about 0.75 – 1 SCFH. Note: the use of the voltmeter is optional, but is useful to determine the length of the calibration time. The sensor requires roughly 1 to 2 minutes to stabilize or until the voltage drop stabilizes.

5. Locate the Low Alarm adjustment pot. labeled “L” in drawing 972300. It is located on the top edge of the Gas-Alert Max board.
6. Also locate the Low Alarm indicator LED (Yellow) which is below the adjustment pots. After the sensor has stabilized, if the Low Alarm LED is already lit then adjust the Low Alarm pot. clockwise until the alarm LED just goes off then adjust it counterclockwise until the LED just comes on, plus 10 degrees. If the LED is already off, adjust the pot. counterclockwise until the LED just goes on, plus 10 degrees.
7. Repeat steps 4 – 6 for the High Alarm using the high level calibration gas, but in this case, use the pot. marked “H” to adjust the alarm, and the leftmost RED LED for the High Alarm indication. See 6.2.3.

THE COMPONENTS IN YOUR KIT

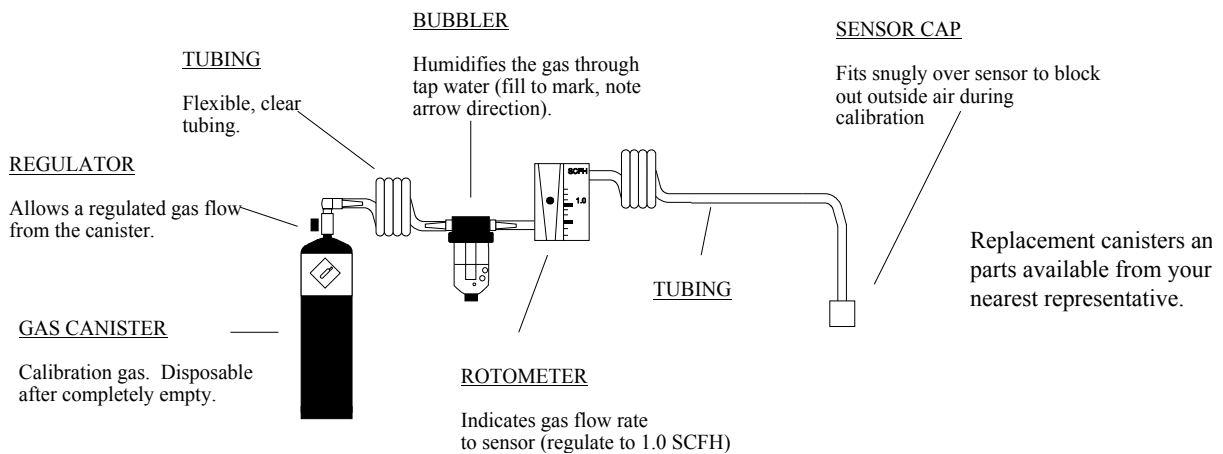

Figure 1.0

6.2.2 SETTING THE TIME DELAY RELAYS

1. **SETTING THE ALARM DELAYS:** The High Alarm Delay-On is the leftmost pot. on the top edge of the Gas Alert board, while the Delay-Off is the 2nd from the left. On delay means relay state will change after “X” minutes after concentration level reaches. Off delay means relay state will stay on “X” minutes after concentration levels are back to normal. Locate the Low Alarm delay pots which are on the top edge of the Gas-Alert Max board and are the 3rd and 4th pots from the left edge. See drawing 972300 for placement. The Delay-On is the leftmost of the group of 2 (3rd from the left edge). Adjust the pots for the desired time delays. Full scale is about 20 minutes so half way is about 10 minutes. This concludes the Low Alarm setup.
2. **TIP:** Setting the delay “ON” for a few minutes will allow the unit to ignore spurious alarms caused by sudden clouds of gas momentarily passing over the sensor. Setting the delay “OFF” for a determined time will keep the fans operating after the sensor has cleared to ensure remote areas from the sensor are also clear.
3. **SETTING THE HORN DELAY:** The audible alarm (optional) is triggered by the High Alarm. The audible alarm delay is therefore in addition to the High Alarm delay. The sequence is as follows: when the gas concentration is higher than the high alarm setpoint for at least the high alarm Delay-On

<u>MODEL</u> GAS-ALERT MAX	<u>DOCUMENT TYPE</u> USER MANUAL	<u>DOCUMENT FILE NAME</u> Mgslmx23.doc	<u>REV.</u> 2.3
<u>CREATE DATE</u> 08/25/97	<u>REV. DATE</u> 10/24/2006	<u>PRINT DATE</u> 10/24/2006	

then the high alarm relay and indicator (RED) are activated. At this time the audible alarm is also triggered. After an additional time as set by the horn delay, the audible alarm is turned on and continues until either the High alarm is deactivated or the silencer switch (Board mounted) is pressed. The horn time delay also has a 0-20 minute scale. The horn may thus be turned on a maximum of about 40 minutes after the sensor senses a high alarm (High Alarm Delay-On plus the Horn Delay-On).

6.2.3 COMPLETION

Replace the cover on the sensor and control box. Remove the flow gauge from the calibration gas. Calibration is complete.

CALIBRATION POTS FOR INTERNAL SENSOR (GAS ALERT & GAS ALERT-PLUS SERIES)

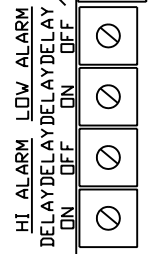

CONNECTION FOR REMOTE PUSH TO TEST



CONNECTION FOR LED'S

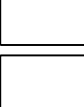

CONNECTION FOR REMOTE SILENCER

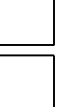

CONNECTION FOR EXTRA HI ALARM DELAY

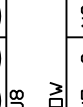

CONNECTION FOR HORN DEL

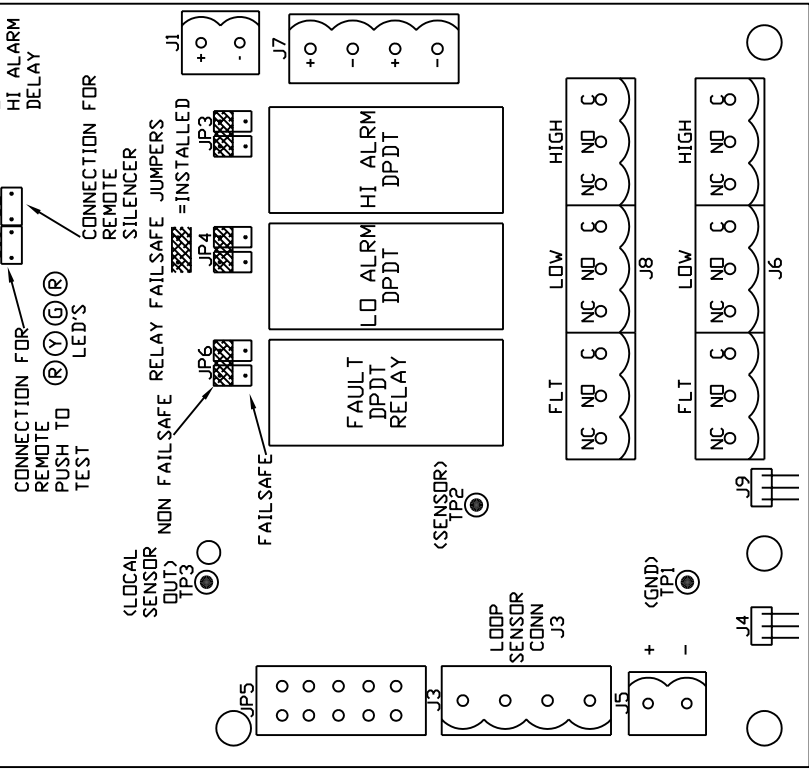

COMMON
HIGH
LOW
FAULT
PCB

+24VDC (+12VDC OPTIONAL)
PGND
VSIG
SGND

+24VDC (+12VDC OPTIONAL)
DR FROM 9000 P/S MOUNTED BELOW

+5V REG FOR LOCAL SENSOR
LOCAL INTEGRAL SENSOR

TO HORN
+24VDC (+12VDC OPTIONAL)

TO BAS/PLC
+24V OUT (+12VDC OPTIONAL)
IN HI ALARM

+24V OUT (+12VDC OPTIONAL)
IN LOW ALARM

CUSTOMER RELAY CONTACTS (COMMON TO ALL SENSORS) RATED 5 AMP 250VAC 5 AMP 30VDC

(NOT INTENDED TO DRIVE APPRECIABLE LOAD. EACH OUTPUT PROTECTED BY 330 OHM RESISTOR)

REV	DATE	DESCRIPTION	CHK'D	APP'D
3	12/21/08	ADDED QUALIFYING TEXT FOR AMPERAGE & RESISTANCE		
2	8/12/98	ADDED TEXT +12VDC OPTIONAL		
1	02/21/97	REVISED TITLE BLOCK		

DATE	BY	DATE	TITLE
03/03/97	A.N.B.	03/03/97	ISA66RLUC & GAS ALERT SERIES PCB LAYOUT

SCALE	REV. DATE	REV.
N.T.S.		1

PROJECT:	972300
ENMET CANADA LTD.	

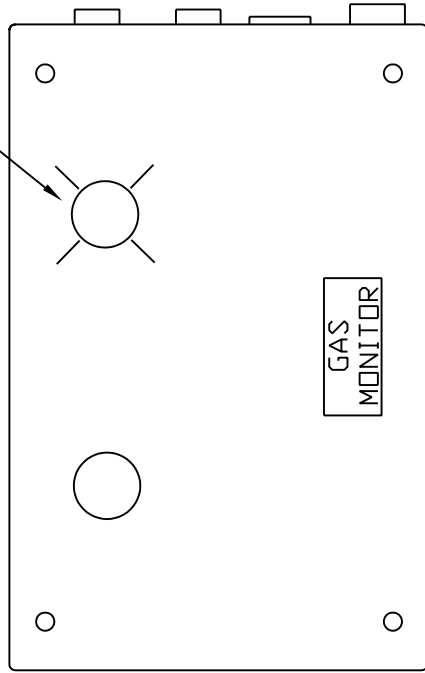

OPTIONAL

WITH COVER

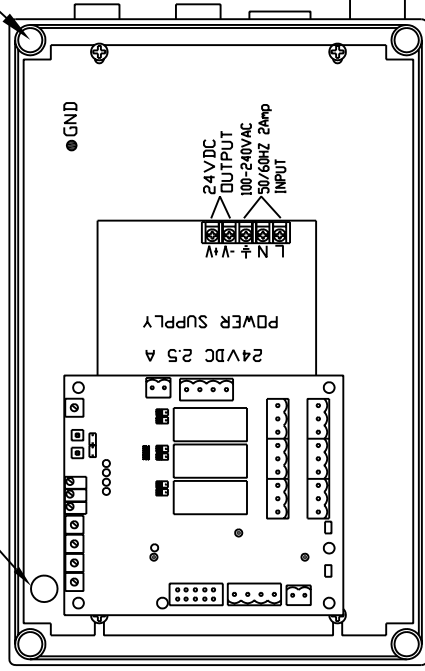

OPTIONAL

WITHOUT COVER

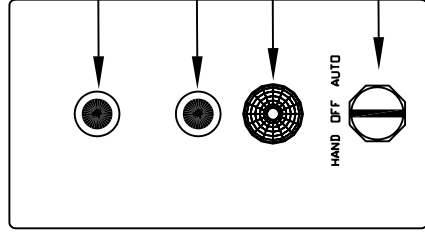

OPTIONAL

RIGHT SIDE VIEW

NOTES:

- 1) ALL DIMENSIONS ARE IN INCHES
- 2) ENCLOSURE IS A RITTAL KL 1503 NEMA 1
- 3) ENCLOSURE DIMENSIONS ARE 11 3/4 X 8 X 5H
- 4) ENCLOSURE MOUNTING DIMENSIONS ARE 10.25 X 6.25
- 5) POWER SUPPLY RATED FOR MAX 8 RLU/MDS SENSORS
(1 INTEGRAL & 7 REMOTE RLU/MDS SENSORS
OR 20 ECGOLD SENSORS)

3	18/05/06	UPDATED NOTE 5
2	28/02/05	CHANGED POWER SUPPLY
1	11/11/03	ADDED FLASHING RED LIGHT AND FLASHER
REV	DATE	DESCRIPTION
REVISIONS		
		PROJECT: _____
BY	DATE	TITLE
DRAWN	A.N.B.	09/10/97
CHECKED		
APPROVED		
SCALE	REF. NOS.	DWG. NO.
N.T.S.		972307
		SHT. 1
		REV. 3

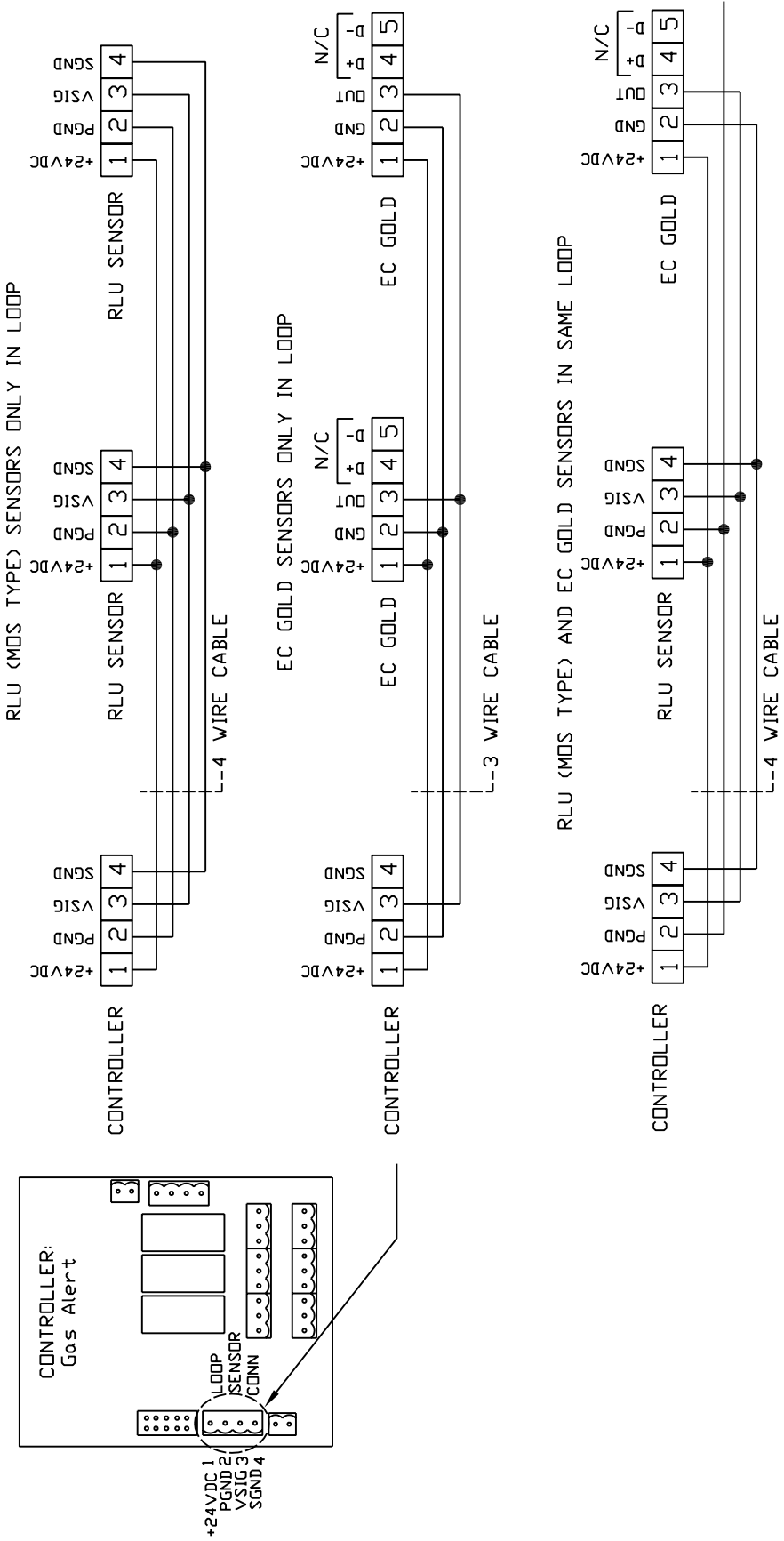

1	11 Jun 01	EC Gold ONLY connection: Use Pgnnd instead of Sgnnd	CHK'D	APP'D
REV	DATE	DESCRIPTION	CHK'D	APP'D

ENMET CANADA		PROJECT:	
		GAS ALERT SERIES	
TITLE		TYPICAL HOOKUP DRAWING	
DATE	BY	DATE	BY
16 05 01	B.C.		
DRAWN	CHECKED	APPROVED	SCALE
			N.T.S.
REF. NOS.	DWG. NO.	SMT.	REV.
	20010201	1	1

The sensors on a loop may be connected in any order i.e. the connection to a sensor may be made from the closest sensor to it.