



# **GAS-ALERT PLUS**

## **User Manual**

# Gas Detection

for Commercial and HVAC Ventilation



GAS-ALERT Series

## THE SYSTEM

The *Gas-Alert* series of gas detection equipment from Arjay has been specifically designed for ventilation control of toxic and combustible gases in commercial, industrial, and residential HVAC installations

This series provides a common set of control relays that are dedicated to control the fans within one area or zone. For multiple fan and zoning needs, the Arjay 66-RLU can be used; to provide one central panel or multiple Gas-Alert systems can be used, one within each zone to provide the control box adjacent to the dedicated fan.

The solid state sensor technology (Metallic Oxide Semiconductor - MOS) provides a low cost and long life approach to gas ventilation. The sensor is calibrated to a target gas selected for the application (ie. carbon monoxide in parking garages). Other toxic gases that may influence the sensor in a similar fashion, such as gasoline and paint fumes, will also initiate ventilation providing added protection from other potentially hazardous vapors. Gas selective sensors are available where background gases are preferred not to activate the fans in conjunction with the target gas (see Multi-Sense Series).

Three standard models will provide you with a system that is right for your specific application.

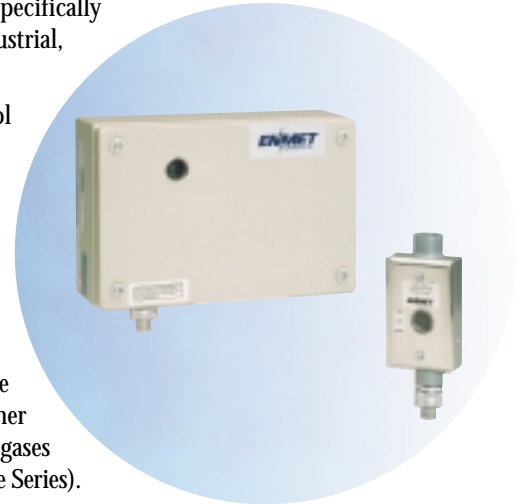

The *Gas-Alert* for single sensor applications. The sensor can be supplied integral to the control unit or remote for detection of gases in awkward spaces.

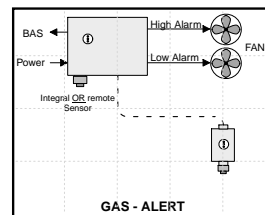

The *Gas-Alert Plus* for dual sensor needs. With one sensor integral to the control unit and one sensor remote, this unit is ideal for loading docks and small private parking garages.

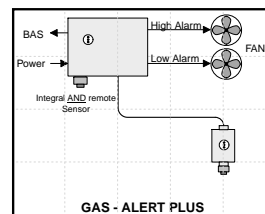

The *Gas-Alert Max* can monitor a run of up to eight sensors in the field. This is ideal for use in larger areas where a common alarm relay is sufficient without the discrete acknowledgement from a specific sensor. The single 4-wire run of shielded cable allows a very economical installation. The sensors can be spliced into any point along the run.

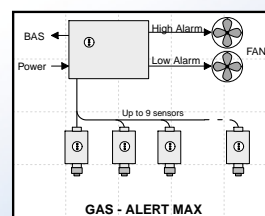

## THE RESULTS

- Solid State Sensor = long life and low cost
- MOS Technology = responds to multiple toxic or combustible gases for added safety
- Single Wire Run = installation economy
- Target Gas Calibration = provides easy one man field calibration

# GAS-ALERT SPECIFICATIONS

<b>SENSOR:</b>	Metallic Oxide Semiconductor (MOS) technology with cindered filter housing for environmental conditioning. Diffusion sensing (no pumps). Plug-in design.	
<b>VISUAL ALARMS:</b>	LED indication at sensor and controller green (normal) yellow (low alarm) red (high alarm) red (fault) (flashing at sensor, steady at controller)	
<b>RELAYS:</b>	5 amp @ 250 VAC, DPDT, Dry; one for high, one for low, one for fault (on multiple sensor units, above relays are common to all sensors)	
<b>TIME DELAYS:</b>	0-20 minute Delay On and Delay Off for each alarm relay 0-20 minute Delay On for audio signal	
<b>BAS INTERFACE:</b>	Low Alarm:	0 volts indicates normal, 24 VDC signal indicates alarm condition
	High Alarm:	0 volts indicates normal, 24 VDC signal indicates alarm condition (for BAS acknowledgement only)
<b>AUDIO OUTPUT:</b>	24 vdc @ 50 mA for optional buzzer On board audio silence (optional external mounted push button)	
<b>FAIL SAFE:</b>	Field selectable for high or low for each relay	
<b>PUSH TO TEST:</b>	On board push button for control function test (optional external mounted push button)	
<b>POWER INPUT:</b>	115 VAC, 50/60 Hz or 24 VDC (.25 amp/sensor). Specify at time of order	
<b>TEMPERATURE:</b>	-20 C to +60 C	
<b>HUMIDITY:</b>	0 to 90% non-condensing. Equipment mounted in non-wetted areas only.	
<b>SENSOR LIFE:</b>	Expected 3 to 5 years	
<b>MAINTENANCE:</b>	Recommended minimum 3 gas calibrations per year. Frequency determined by application.	
<b>APPROVALS:</b>	CSA, cUL and UL Electrical Safety.	
<b>TYPICAL GASES:</b>	Typical Gases	Typical Calibration Setpoints (2 levels/sensor)
	Carbon Monoxide:	ppm: 25, 35, 50, 75, 100, 200
	Ammonia:	ppm: 25, 35, 50, 100, 500
	A1 Refrigerants	ppm: 1000 only, (R-11, R-12, R-22, R-134A)
	B1 Refrigerants	ppm: 30 or 50 only, (R-123)
	Methane	% lel: 5, 10, 15, 20, 25, 35, 40, 50
	Propane	% lel: 5, 10, 15, 20
	Hydrogen	% lel: 10, 20

One target gas per sensor only. Multiple sensors may be calibrated to different gases along the same wire run. Correlation gases and specialty calibrations are available. Specify calibration at time of order.

**YOUR REPRESENTATIVE:** Enmet Canada Ltd.  
Oakville (Toronto), Canada L6H 6C9  
Tel: ++1 (905) 829-4700  
1-800-367-4706 (Canada)  
Fax: ++1 (905) 829-4701

enmet@arjayeng.com  
www.EnmetGasDetection.com

<u>MODEL</u> <b>ENMET</b> <b>GAS-ALERT PLUS</b>	<u>DOCUMENT TYPE</u> USER MANUAL	<u>DOCUMENT FILE NAME</u> REV. Mgs1PL20.doc 2.0
<u>CREATE DATE</u> 08/25/97	<u>REV. DATE</u> 06/16/2003	<u>PRINT DATE</u> 06/16/2003

## TABLE OF CONTENTS

1.0	THEORY OF OPERATION.....	3
2.0	UNPACKING.....	3
3.0	SENSOR LOCATION.....	3
4.0	INSTRUMENT OVERVIEW.....	4
4.1	FEATURES.....	4
4.2	DESCRIPTION.....	4
4.3	SPECIFICATIONS.....	4
5.0	INSTALLATION.....	5
5.1	MECHANICAL INSTALLATION.....	5
5.2	ELECTRICAL HOOKUP.....	5
5.2.1	POWER.....	5
5.2.2	REMOTE SENSOR.....	5
5.2.3	RELAYS.....	5
5.2.4	BUILDING AUTOMATION SYSTEM (BAS) CONNECTION.....	6
5.2.5	AUDIBLE ALARM (Optional).....	6
6.0	CALIBRATION AND SETUP.....	6
6.1	CALIBRATION OF INTEGRAL MOS SENSOR.....	6
6.2.1	CALIBRATING THE INTEGRAL SENSOR.....	6
6.2.2	SETTING THE TIME DELAY RELAYS.....	7
6.2.3	COMPLETION.....	8

<b>MODEL</b> ENMET GAS-ALERT PLUS	<b>DOCUMENT TYPE</b> USER MANUAL	<b>DOCUMENT FILE NAME</b> REV. Mgs1PL20.doc 2.0
<b>CREATE DATE</b> 08/25/97	<b>REV. DATE</b> 06/16/2003	<b>PRINT DATE</b> 06/16/2003

## 1.0 THEORY OF OPERATION

The Gas-Alert Plus is a single zone monitor with two alarm points which employs Metallic Oxide Semiconductor (RLU MOS Series) sensing elements and/or Electrochemical sensors (EC-Gold Series). In the presence of a gas, a voltage output is produced. Depending on the specified gas level, this output enables the activation of alarms, relays, etc. at desired levels. The MOS technology is also referred to as Broad Range sensing because the sensor will respond to a *broad range* of gases. The Electrochemical sensors (EC-Gold Series) may be referred to "wet chem" or "near specific".

The sensor selected for this unit has been determined to be the most suitable for your target gas. The unit and sensor have been calibrated to specific alarm levels using the target gas for this application (i.e. carbon monoxide).

Other toxic or combustible gases may also cause the sensor to respond and alarm the unit. The sensors should be installed in areas where influencing background gases are not constantly present.

Your Enmet gas detector is the state of the art in gas detection, but like any other part of your ventilation system, it requires periodic maintenance and calibration.

The MOS sensors and the Carbon Monoxide (EC-Gold) used in your new gas detector will have a normal operating life of 3 to 5 years under ambient conditions. The other EC-Gold Series sensors will last about 1-2 years. You should consider a preventive maintenance schedule whereby you test your system on a periodic basis to ensure its proper calibration and operation.

Most users have their unit tested every three to four months with test gas. This is a simple procedure, which will indicate any problems with your system. A sensor fault is indicated for the MOS and Carbon Monoxide (EC-Gold Series) sensor only. Other electrochemical sensors are not acknowledged when their operating life has expired.

A test and calibration kit may be purchased from Enmet for this purpose. Parts are also readily available from our facility.

## 2.0 UNPACKING

Inspect all parts of the gas detector upon receipt for any damages that may have occurred during shipping and that all parts ordered were received. Contact Enmet Canada or your local representative if anything is in error or damage is suspected.

## 3.0 SENSOR LOCATION

Gases of different molecular structures have different densities; some are heavier than air and concentrate at the bottom of a space and some will rise.

The following is a general guide. For assistance in sensor location consult your Enmet Representative.

Carbon Monoxide	same as air	place about 4-6' above finished floor
Methane	lighter than air	place near ceiling
Ammonia	lighter than air	place near ceiling
Propane	heavier than air	place about 2' above finished floor
H2S	heavier than air	place about 2' above finished floor
Freon	heavier than air	place about 2' above finished floor

NOTE: Place sensors in a location that is easily accessible for calibration and testing. Mount so the sensors are

<b>HARDWARE REV.</b> 1.0	<b>SOFTWARE REV.</b> N/A	Page 3 of 8
-----------------------------	-----------------------------	-------------

<b>MODEL</b> ENMET GAS-ALERT PLUS	<b>DOCUMENT TYPE</b> USER MANUAL	<b>DOCUMENT FILE NAME</b> REV. Mgs1PL20.doc 2.0
<b>CREATE DATE</b> 08/25/97	<b>REV. DATE</b> 06/16/2003	<b>PRINT DATE</b> 06/16/2003

facing downward to avoid dust or debris collection on the sensor.

## 4.0 INSTRUMENT OVERVIEW

### 4.1 FEATURES

- Supports one integral MOS sensor and up to 1 Enmet Remote MOS RLU Sensors or 2 Enmet Remote MOS RLU Sensors or 5 Remote EC-Gold Series Sensors.
- DPDT 250 VAC / 5A relay contacts for High, Low and Sensor Fault alarms
- Adjustable / independent 0-20 minute time delay to on and delay to off for High and Low alarms
- Independent Fail-Safe setting for High and Low alarms
- Board level Audible alarm output with silencer. Remote audible alarm & silencer push-button optional
- Adjustable time delay for Audible Alarm (delay starts after High alarm)
- Board level Push to Test button. Remote Push to Test push-button optional.
- Additional High and Low alarm outputs (+24V out) to Building Automation System (BAS)

### 4.2 DESCRIPTION

The Enmet Gas-Alert Plus detection systems offer the ability to monitor for a variety of gases. It offers DPDT contacts for High, Low and Sensor Fault alarms. In addition, High and Low signals are also available for connection to a Building Management System (BMS). High and Low alarms have independent Delay-ON and Delay-Off time delays adjustable from 0 – 20 minutes (total of 4 delay adjustments).

### 4.3 SPECIFICATIONS

#### FUNCTION

Two level alarm system: High and Low Alarms plus Sensor Fault Alarm

#### SENSOR TYPE

MOS (Metal Oxide Semiconductor) or Electrochemical Sensor (EC-Gold)

#### GASES

CO, Propane, CH<sub>4</sub>, NH<sub>3</sub>, H<sub>2</sub>S, Cl<sub>2</sub>, NO<sub>2</sub> (consult factory for others)

#### ALARM RELAYS

Relays 3 DPDT relays for High, Low and Sensor Fault Alarms  
 Contacts 250 VAC or 30 VDC @ 5A  
 Fail-Safe Fail-Safe / non-fail-safe settings for all 3 relays  
 Time Delay 0 – 20 minutes. Independent Delay-On and Delay-Off for both High and Low Alarm relays (total 4 delay adjustments)

#### BAS OUTPUTS

Signal output High and Low Alarm status outputs. +24V when alarm is active, 0V if not. The status signals reflect the alarm condition AFTER the corresponding alarm delays i.e. the status signal is active while the corresponding alarm light is active.  
 Drive capability The status signals are meant to be connected to a BAS / PLC and are not intended to drive any appreciable load. A 330 Ohm resistor protects each output. Thus for a 500 Ohm load, the output voltage is 14.5V, and for a 1000 Ohm load the output voltage is 18.0V.

#### AUDIBLE ALARM (Optional)

Function Activated on High Alarm. (After High Alarm Delay)  
 Drive capability 24V @ 50 mA max. If greater drive is required, use a slave relay.  
 Silencer Push-button silencer (auto-reset). Connection for remote silencer push-button (optional)  
 Time Delay 0 – 20 minutes Delay – On. (In addition to High Alarm Delay-On).

#### DIAGNOSTICS

<b>HARDWARE REV.</b> 1.0	<b>SOFTWARE REV.</b> N/A	Page 4 of 8
-----------------------------	-----------------------------	-------------

<b>MODEL</b> ENMET GAS-ALERT PLUS	<b>DOCUMENT TYPE</b> USER MANUAL	<b>DOCUMENT FILE NAME</b> REV. Mgs1PL20.doc 2.0
<b>CREATE DATE</b> 08/25/97	<b>REV. DATE</b> 06/16/2003	<b>PRINT DATE</b> 06/16/2003

Push to Test push-button. Tests by forcing a Sensor Fault on the internal sensor. Alarm lights, relays, and BAS status signals are tested. Note: the time delay settings are still active during test. Adjust them to 0 minutes prior to test if the time delays are not to be tested.

## POWER

Internal sensor only	115 VAC @ .5 A, when supplied with a power supply (220 VAC available) 24 VDC @ 0.5A max. (Standard).
Remote Sensor System	24 VDC @ 0.5A + 0.25A per Remote MOS Sensor /100mA per Electrochemical (EC-Gold Sensor)

## MECHANICAL SPECIFICATIONS

Enclosure	Nema 4X, Epoxy Coated Steel
Dimensions	8" X 8" X 5"
Weight	6.5 lb.

## ENVIRONMENTAL SPECIFICATIONS

Operating Temp.	-20 to 60 Deg. C
Relative Humidity	90% max. with no condensation.

## 5.0 INSTALLATION

### 5.1 MECHANICAL INSTALLATION

See Drawing 972307

### 5.2 ELECTRICAL HOOKUP

See drawing 972300

#### 5.2.1 POWER

The standard power input is 24 VDC. If this is being used then locate the power supply connector at the bottom left of the Gas-Alert Plus board and connect the 24 VDC as shown on drawing 972300. The connector is a 2-conductor mating pair arrangement. The connector may be unplugged for ease of wiring.

If 115 or 220 VAC power is to be used then locate the separate VAC input power supply and connect the Line, Neutral and GND connections as labeled on the back panel.

#### 5.2.2 REMOTE SENSOR

The Gas-Alert Plus may have one integral MOS sensor and remote MOS/EC Gold sensors. The remote MOS sensor is connected via a 4-conductor 16-18 gauge shielded wire, cable that carries power (2 conductors) and a common remote signal pair. The Electrochemical (EC-Gold Series) is connected via a 3 conductor 16-18 gauge shielded wire. See dwg 20010201 for more details.

Locate the Remote Sensor connector on the left edge of the Gas-Alert Plus board.

#### 5.2.3 RELAYS

Three DPDT 250 VAC / 5A contact relays are provided: for High Alarm, Low Alarm, and Sensor Fault. These relays are common to the integral sensor and the remote sensors, i.e. if the integral sensor or the remote sensor is in low alarm then the Low Alarm relay and LED are activated.

Sensor Fault: If any MOS sensor (integral or remote) or the Carbon Monoxide (EC-Gold Series) is removed then the Sensor Fault relay and LED are activated.

NOTE: Each relay may be set as Fail-Safe (normally energized, and de-energized on alarm condition) or

<b>HARDWARE REV.</b> 1.0	<b>SOFTWARE REV.</b> N/A	Page 5 of 8
-----------------------------	-----------------------------	-------------

<b>MODEL</b> ENMET GAS-ALERT PLUS	<b>DOCUMENT TYPE</b> USER MANUAL	<b>DOCUMENT FILE NAME</b> REV. Mgs1PL20.doc 2.0
<b>CREATE DATE</b> 08/25/97	<b>REV. DATE</b> 06/16/2003	<b>PRINT DATE</b> 06/16/2003

non-fail-safe (normally de-energized, and energized on alarm condition).

The connections are as shown on drawing 972300.

## 5.2.4 BUILDING AUTOMATION SYSTEM (BAS) CONNECTION

The Gas-Alert Plus provides external High and Low Alarm status signals (+24V when in alarm, 0 V when not) for connection to a Building Automation System (BAS). The signals are non-isolated and are referenced to the provided +24V power supply ground.

The connection is located on the right edge of the Gas-Alert Max board as shown on drawing 972300.

## 5.2.5 AUDIBLE ALARM (Optional)

The Audible Alarm connector (2 conductor) is located on the right edge of the Gas-Alert Plus board. The connection is either to a Horn / Buzzer on the side panel (typical) OR connected to a remote horn / buzzer (both optional). The output is +24V @ 50 mA (maximum current). Some horns / buzzers are polarity sensitive i.e. make sure the + output is connected to the + terminal of the horn.

# 6.0 CALIBRATION AND SETUP

## 6.1 CALIBRATION OF INTEGRAL MOS SENSOR

The Gas-Alert Plus may have up to 2 RLU MOS sensors (all remote or one integral and the rest remote) or up to 5 Electrochemical (EC-GOLD Series) sensors. **The integral sensor may be only of the MOS technology.** See the following calibration procedures for the integral sensor. If other sensors are supplied, please find the additional sensor manual(s) required at the end of this manual.

### 6.2.1 CALIBRATING THE INTEGRAL SENSOR

**NOTE:** If an integral sensor is not being used a resistor is factory jumpered across the input terminal block (J9). Verify this is in place and proceed to 6.2.2

Calibrating the integral sensor requires:

- Enmet Calibration Kit which should have calibration gas concentrations for the required High and Low alarm values.
  - Small slot screwdriver to adjust the alarm levels.
  - The Gas-Alert Plus should be powered up for 48 hours prior to calibration to allow the sensor to stabilize.
  - A Voltmeter.
1. Locate Test Point 1 (named TP1: Black) (See drawing 972300). It is located at the bottom left of the Gas-Alert Plus board. Locate Test Point 2 (named TP2: Red). It is located roughly an inch above TP1. Plug the negative lead of the voltmeter into TP1 and the positive lead to TP2. The measured voltage will be in the 1.5 – 5 Volt range.
  2. Locate the Range potentiometer (labeled N) on the top edge of the Gas-Alert Plus board. With the small adjusting screw, adjust the pot. to get approx. 2.8 VDC (+/- .2) volts on the voltmeter in clean air.
  3. Prior to calibration, adjust all 4 time delay pots to 0: fully counter clockwise. The delay adjust pots are in a group of 4 located on the top left edge of the Gas-Alert Max board.
  4. **SETTING THE LOW ALARM:** Setup the Enmet calibration kit as per the Enmet calibration kit drawing (see fig 1.0). You will need a gas canister containing the gas concentration of the low alarm level (i.e. if the low alarm is to be set at 35 PPM Carbon Monoxide then the canister should contain 35

<b>HARDWARE REV.</b> 1.0	<b>SOFTWARE REV.</b> N/A	Page 6 of 8
-----------------------------	-----------------------------	-------------

<b>MODEL</b> ENMET GAS-ALERT PLUS	<b>DOCUMENT TYPE</b> USER MANUAL	<b>DOCUMENT FILE NAME</b> REV. Mgs1PL20.doc 2.0
<b>CREATE DATE</b> 08/25/97	<b>REV. DATE</b> 06/16/2003	<b>PRINT DATE</b> 06/16/2003

PPM Carbon Monoxide). Attach the calibration cup over the Gas-Alert Plus integral sensor and adjust the gas flowrate to about 0.75 – 1 SCFH. Note: the use of the voltmeter is optional, but is useful to determine the length of the calibration time. The sensor requires roughly 1 to 2 minutes to stabilize or until the voltage drop stabilizes.

5. Locate the Low Alarm adjustment pot. labeled “L” in drawing 972300. It is located on the top edge of the Gas-Alert Plus board.
6. Also locate the Low Alarm indicator LED (Yellow) which is below the adjustment pots. After the sensor has stabilized, if the Low Alarm LED is already lit then adjust the Low Alarm pot. clockwise until the alarm LED just goes off then adjust it counterclockwise until the LED just comes on, plus 10 degrees. If the LED is already off, adjust the pot. counterclockwise until the LED just goes on, plus 10 degrees.
7. Repeat steps 4 – 6 for the High Alarm using the high level calibration gas, but in this case, use the pot. marked “H” to adjust the alarm, and the leftmost RED LED for the High Alarm indication. See 6.2.3.

## THE COMPONENTS IN YOUR KIT

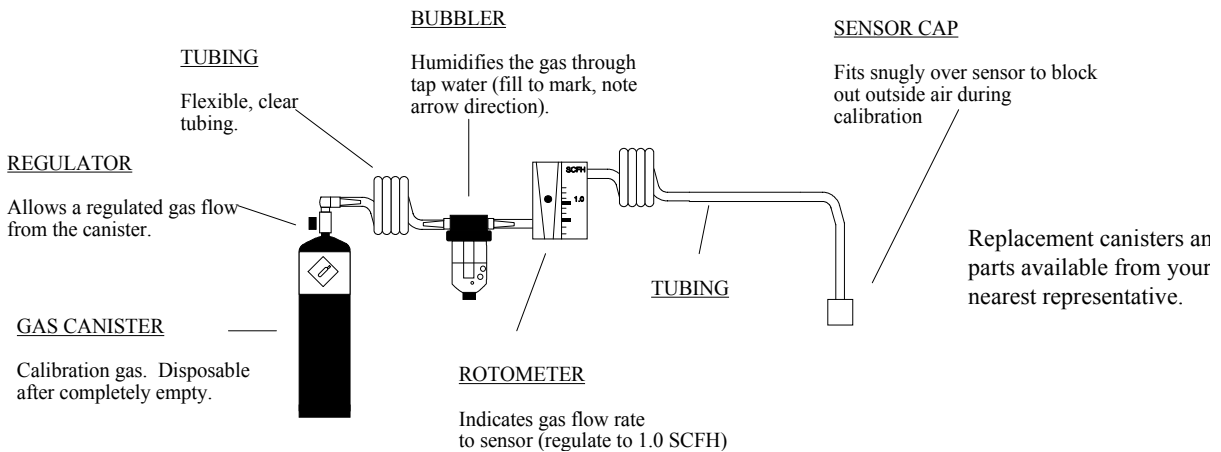

**Figure 1.0**

### 6.2.2 SETTING THE TIME DELAY RELAYS

1. **SETTING THE ALARM DELAYS:** The High Alarm Delay-On is the leftmost pot. on the top edge of the Gas Alert board, while the Delay-Off is the 2<sup>nd</sup> from the left. On delay means relay state will change after “X” minutes after concentration level reaches. Off delay means relay state will stay on “X” minutes after concentration levels are back to normal. Locate the Low Alarm delay pots which are on the top edge of the Gas-Alert Plus board and are the 3<sup>rd</sup> and 4<sup>th</sup> pots from the left edge. See drawing 972300 for placement. The Delay-On is the leftmost of the group of 2 (3<sup>rd</sup> from the left edge). Adjust the pots for the desired time delays. Full scale is about 20 minutes so half way is about 10 minutes. This concludes the Low Alarm setup.
2. **TIP:** Setting the delay “ON” for a few minutes will allow the unit to ignore spurious alarms caused by sudden clouds of gas momentarily passing over the sensor. Setting the delay “OFF” for a determined time will keep the fans operating after the sensor has cleared to ensure remote areas from the sensor are also clear.
3. **SETTING THE HORN DELAY:** The audible alarm (optional) is triggered by the High Alarm. The audible alarm delay is therefore in addition to the High Alarm delay. The sequence is as follows: when the gas concentration is higher than the high alarm setpoint for at least the high alarm Delay-On

<u>MODEL</u> <b>ENMET GAS-ALERT PLUS</b>	<u>DOCUMENT TYPE</u> USER MANUAL	<u>DOCUMENT FILE NAME</u> REV. Mgs1PL20.doc 2.0
<u>CREATE DATE</u> 08/25/97	<u>REV. DATE</u> <b>06/16/2003</b>	<u>PRINT DATE</u> <b>06/16/2003</b>

then the high alarm relay and indicator (RED) are activated. At this time the audible alarm is also triggered. After an additional time as set by the horn delay, the audible alarm is turned on and continues until either the High alarm is deactivated or the silencer switch (Board mounted) is pressed. The horn time delay also has a 0-20 minute scale. The horn may thus be turned on a maximum of about 40 minutes after the sensor senses a high alarm (High Alarm Delay-On plus the Horn Delay-On).

### **6.2.3 COMPLETION**

Replace the cover on the sensor and control box. Remove the flow gauge from the calibration gas. Calibration is complete.

CALIBRATION POTS FOR INTERNAL SENSOR (GAS ALERT & GAS ALERT-PLUS SERIES)

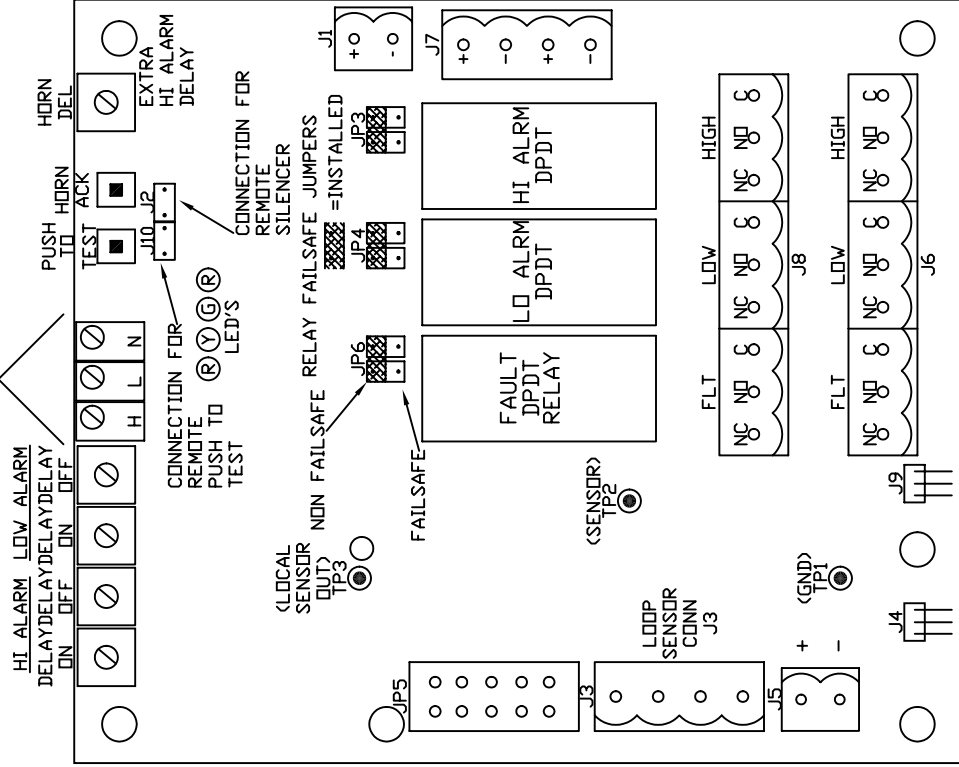

COMMON  
HIGH  
LOW  
FAULT  
PCB

DC OPTIONAL)  
PGND  
VSIG  
SGND

DC OPTIONAL)  
OR  
FROM  
9000 P/S  
MOUNTED  
BELOW

TO HORN  
+24VDC (+12VDC OPTIONAL)

+24V OUT (+12VDC OPTIONAL)  
IN HI  
ALARM

+24V OUT (+12VDC OPTIONAL)  
IN LOW  
ALARM

TO BAS/PLC

(NOT INTENDED TO  
DRIVE APPRECIABLE  
LOAD. EACH OUTPUT  
PROTECTED BY 330  
OHM RESISTOR)

CUSTOMER  
RELAY CONTACTS  
(COMMON TO ALL SENSORS)  
RATED 5 AMP 250VAC  
5 AMP 30VDC

REV	DATE	DESCRIPTION	CHKD	APP'D
3	15/21/01	ADDED QUALIFYING TEXT FOR AMPERAGE & RESISTANCE		
2	8/13/98	ADDED TEXT +12VDC OPTIONAL		
1	8/21/97	REVISED TITLE BLOCK		

REVISIONS

PROJECT:  
ENMET CANADA LTD.

DATE	BY	DATE	BY	TITLE
08/21/97	A.N.B.	08/03/97		ISA66RLUC & GAS ALERT SERIES PCB LAYOUT
08/21/97				
08/21/97				
08/21/97				

REF: DWG. NO. 972300  
SCALE N.T.S.  
SHEET 1 OF 3

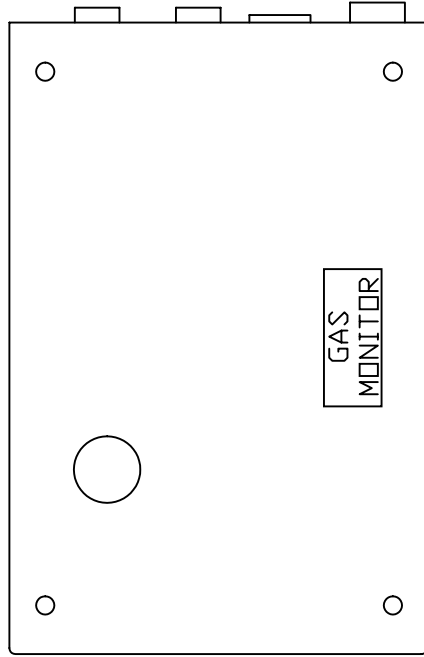

Ø0.150  
(FOR MOUNTING)

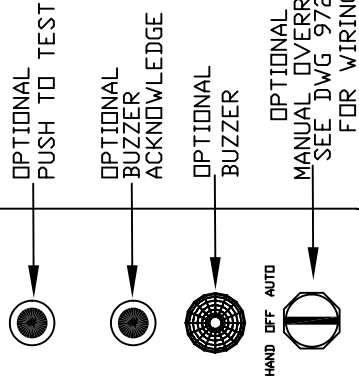
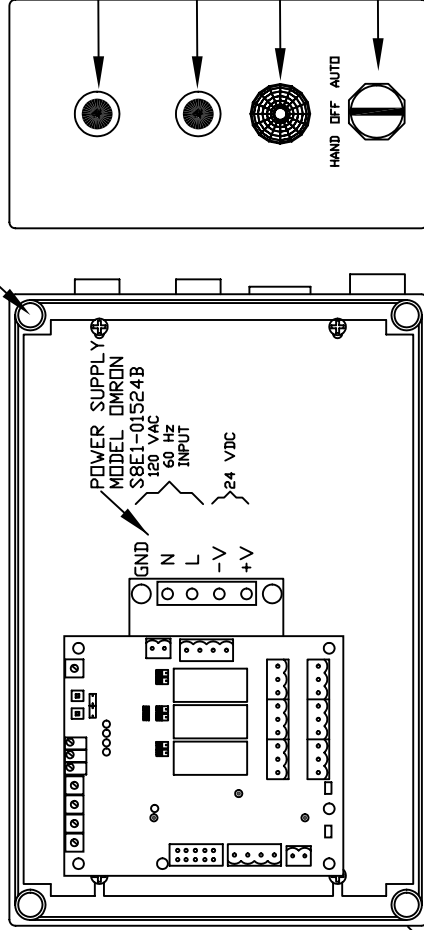

OPTIONAL  
WITH COVER

OPTIONAL  
WITHOUT COVER

OPTIONAL  
RIGHT SIDE VIEW

4 - WIRE, 18 AWG SHIELDED

FIELD SENSOR

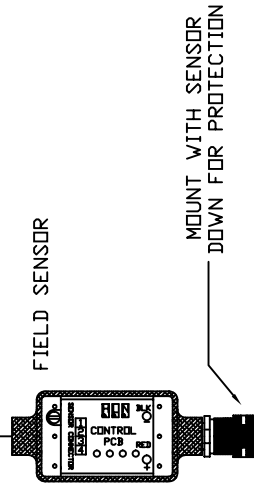

NOTES:  
 POWER SUPPLY RATED FOR MAX 2 SENSORS (1 REMOTE & 1 INTEGRAL)  
 ALL DIMENSIONS ARE IN INCHES  
 ENCLOSURE IS A RITTAL KL 1503  
 ENCLOSURE DIMENSIONS ARE 11 3/4 X 8 X 5H  
 ENCLOSURE MOUNTING DIMENSIONS ARE 10.25 X 6.25  
 NEMA 1

REV	DATE	DESCRIPTION	CHKD	APPD

REVISIONS		PROJECT:	
ENMET CANADA LTD		GAS-ALERT PLUS	
ENCLOSURE DRAWING		ENCLOSURE DRAWING	

ENG. STATUS	BY	DATE	REV.	NO.	SCALE	N.T.S.
DRAWN	A.N.B.	09/10/97	1	0	972306	1
CHECKED						
APPROVED						

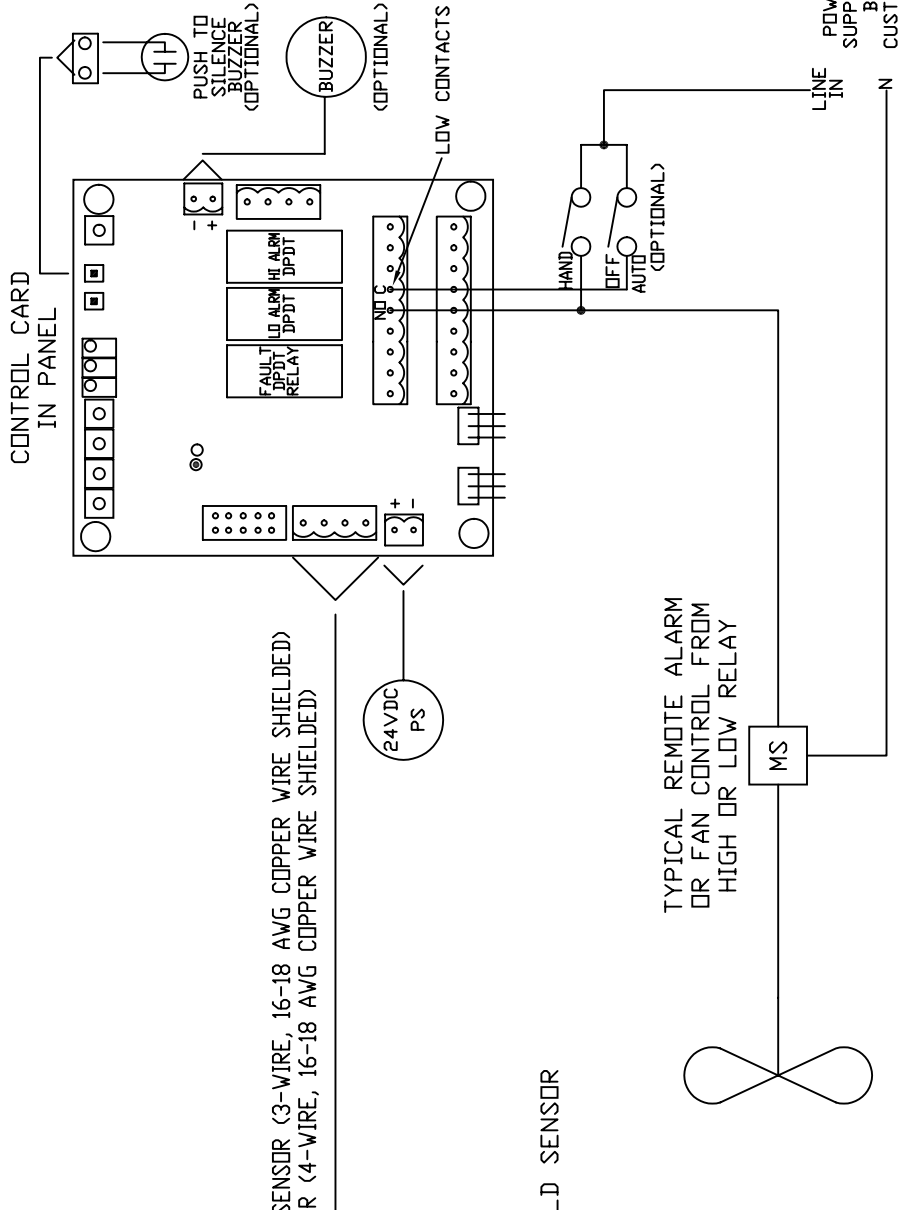

SENSOR (3-WIRE, 16-18 AWG COPPER WIRE SHIELDED)  
 R (4-WIRE, 16-18 AWG COPPER WIRE SHIELDED)

-D SENSOR

TYPICAL REMOTE ALARM  
 OR FAN CONTROL FROM  
 HIGH OR LOW RELAY

MS

LINE IN  
 POWER SUPPLIED  
 BY  
 CUSTOMER

4	7/4/03	ADDED TORQUE RATINGS ON ALL BLZ CONNECTORS
3	8/10/01	ADDED ADDITIONAL WIRING TEXT
2	8/5/01	CHANGED TO GENERIC SENSOR HOUSING, EDITED TEXT
1	16/4/99	ADDED PUSH TO SILENCE
REV	DATE	DESCRIPTION

REVISIONS

PROJECT: ENMET CANADA LTD.

DATE	BY	DATE	BY	TITLE
09/09/97	A.N.B.	09/09/97		SYSTEM OVERVIEW FOR
				ISA-66RLU-C, & GAS ALERT SERIE
				WITH MANUAL OVERRIDE
APPROVED	REF. SYMBOL	DATE	SCALE	N.T.S.

972801

1

4

VALUE RATINGS ON ALL BLZ CONNECTORS  
 TORQUE TERMINAL BLOCKS IS 4-5 Nm

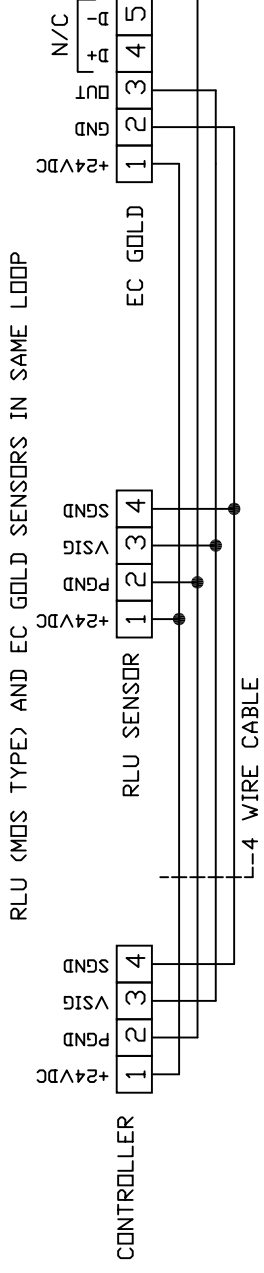
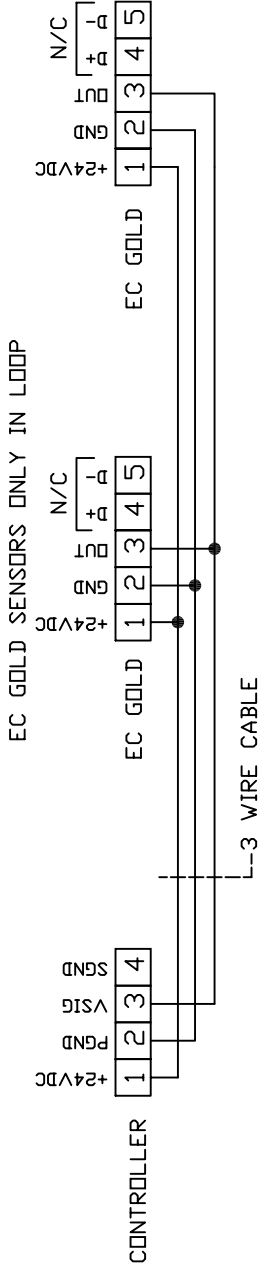
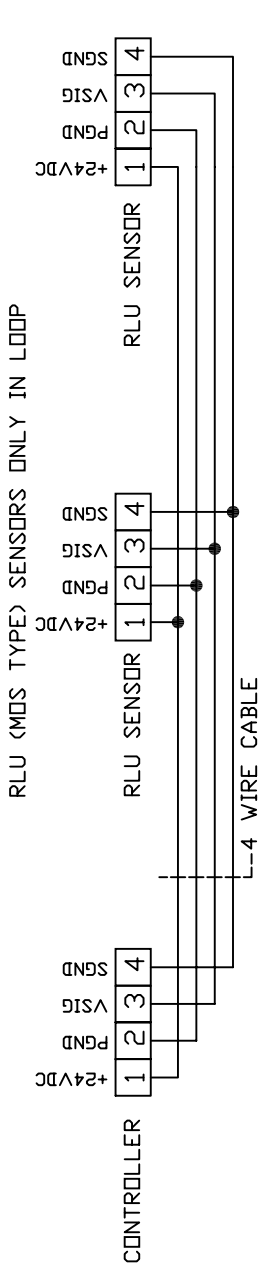

In a loop may be connected in the connection to a sensor from the closest sensor to it.

1	11 Jun 01	EC Gold ONLY connection: Use Pcmd instead of Scmd	CHK'D	APP
REV	DATE	DESCRIPTION		
REVISIONS				
ENMET CANADA		PROJECT:		
		GAS ALERT SERIES		
DWG. STATUS	BY	DATE	TITLE	
DRAWN	B.C.	16 05 01	TYPICAL HOOKUP DRAWING	
CHECKED				
APPROVED				
SCALE	REF. NOS.	DWG. NO.	REV.	SHT.
N.T.S.		20010201	1	1