



GAS-ALERT

User Manual

<u>MODEL</u> Enmet GAS-ALERT	<u>DOCUMENT TYPE</u> USER MANUAL	<u>DOCUMENT FILE NAME</u> mgslrt15.doc	<u>REV.</u> 1.5
<u>CREATE DATE</u> 08/25/97	<u>REV. DATE</u> 3/29/2004	<u>PRINT DATE</u> 3/29/2004	

TABLE OF CONTENTS

1.0 THEORY OF OPERATION	3
2.0 UNPACKING	3
3.0 SENSOR LOCATION	3
4.0 INSTRUMENT OVERVIEW	4
4.1 FEATURES	4
4.2 DESCRIPTION	4
4.3 SPECIFICATIONS	4
5.0 INSTALLATION	5
5.1 MECHANICAL INSTALLATION	5
5.2 ELECTRICAL HOOKUP	5
5.2.1 POWER	5
5.2.2 REMOTE SENSOR	5
5.2.3 RELAYS	5
5.2.4 BUILDING AUTOMATION SYSTEM (BAS) CONNECTION	6
5.2.5 AUDIBLE ALARM (Optional)	6
6.0 CALIBRATION AND SETUP	6
6.1 CALIBRATION	6
6.2.1 CALIBRATING THE INTEGRAL SENSOR	6
6.2.2 CALIBRATING THE REMOTE SENSOR	7
6.2.3 SETTING THE TIME DELAY RELAYS	8
6.2.4 COMPLETION	8

<u>MODEL</u> Enmet GAS-ALERT	<u>DOCUMENT TYPE</u> USER MANUAL	<u>DOCUMENT FILE NAME</u> mgslrt15.doc	<u>REV.</u> 1.5
<u>CREATE DATE</u> 08/25/97	<u>REV. DATE</u> 3/29/2004	<u>PRINT DATE</u> 3/29/2004	

1.0 THEORY OF OPERATION

The Gas-Alert has a Metallic Oxide Semiconductor (MOS) sensing element in its detector head. In the presence of a gas an output is produced, enabling the activation of alarms, relays, etc. at specific levels. This technology is also referred to as Broad Range sensing because the sensor will respond to a *broad range* of gases.

The sensor selected for this unit has been determined to be the most suitable for your target gas. The unit and sensor have been calibrated to specific alarm levels using the target gas for this application (i.e. carbon monoxide).

Other toxic or combustible gases may also cause the sensor to respond and alarm the unit. The sensors should be installed in areas where influencing background gases are not constantly present.

Your Enmet gas detector is the state of the art in gas detection, but like any other part of your ventilation system, it requires periodic maintenance and calibration.

The sensors used in your new gas detector are solid state and will have a normal operating life of 3 to 5 years under ambient conditions. You should consider a preventive maintenance schedule whereby you test your system on a periodic basis to ensure its proper calibration and operation.

Most users have their unit tested every three to four months with test gas. This is a simple procedure which will indicate any problems with your system.

A test and calibration kit may be purchased from Enmet for this purpose. Parts are also readily available from our facility.

2.0 UNPACKING

Inspect all parts of the gas detector upon receipt for any damage that may have occurred during shipping and that all parts ordered were received. Contact Enmet Canada or your local representative if anything is in error or damage is suspected.

3.0 SENSOR LOCATION

Gases of different molecular structures have different densities; some are heavier than air and concentrate at the bottom of a space and some will rise.

The following is a general guide. For assistance in sensor location consult your Enmet Representative.

Carbon Monoxide	same as air	place about 4-6' above finished floor
Methane	lighter than air	place near ceiling
Ammonia	lighter than air	place near ceiling
Propane	heavier than air	place about 2' above finished floor
H2S	heavier than air	place about 2' above finished floor
Freon	heavier than air	place about 2' above finished floor

NOTE: Place sensors in a location that is easily accessible for calibration and testing. Mount so the sensors are facing downward to avoid dust or debris collection on the sensor.

<u>MODEL</u> Enmet GAS-ALERT	<u>DOCUMENT TYPE</u> USER MANUAL	<u>DOCUMENT FILE NAME</u> mgsirt15.doc	<u>REV.</u> 1.5
<u>CREATE DATE</u> 08/25/97	<u>REV. DATE</u> 3/29/2004	<u>PRINT DATE</u> 3/29/2004	

4.0 INSTRUMENT OVERVIEW

4.1 FEATURES

- Supports one integral sensor or one Enmet Remote Sensor
- Long life MOS sensors (3 - 5 years)
- DPDT 250 VAC / 5A relay contacts for High, Low and Sensor Fault alarms
- Adjustable / independent 0-20 minute time delay to on and delay to off for High and Low alarms
- Independent Fail-Safe setting for High and Low alarms
- Board level Audible alarm output with silencer. Remote audible alarm & silencer push-button optional
- Adjustable time delay for Audible Alarm (delay starts after High alarm)
- Board level Push to Test button. Remote Push to Test push-button optional.
- Additional High and Low alarm outputs (+24V out) to Building Automation System (BAS)

4.2 DESCRIPTION

The Enmet Gas-Alert detection systems offer the ability to monitor for a variety of gases.

It offers DPDT contacts for High, Low and Sensor Fault alarms. In addition, High and Low signals are also available for connection to a Building Management System (BMS). High and Low alarms have independent Delay-ON and Delay-Off time delays adjustable from 0 – 20 minutes (total of 4 delay adjustments).

4.3 SPECIFICATIONS

FUNCTION

Two level alarm system: High and Low Alarms plus Sensor Fault Alarm

SENSOR TYPE

MOS (Metal Oxide Semiconductor) Sensor

GASES

CO, Propane, Methane, Ammonia (consult factory for others)

ALARM RELAYS

Relays	3 DPDT relays for High, Low and Sensor Fault Alarms
Contacts	250 VAC or 30 VDC @ 5A
Fail-Safe	Fail-Safe / non-fail-safe settings for all 3 relays
Time Delay	0 – 20 minutes. Independent Delay-On and Delay-Off for both High and Low Alarm relays (total 4 delay adjustments)

BAS OUTPUTS

Signal output	High and Low Alarm status outputs. +24V when alarm is active, 0V if not. The status signals reflect the alarm condition AFTER the corresponding alarm delays i.e. the status signal is active while the corresponding alarm light is active.
Drive capability	The status signals are meant to be connected to a BAS / PLC and are not intended to drive any appreciable load. Each output is protected by a 330 Ohm resistor. Thus for a 500 Ohm load, the output voltage is 14.5V, and for a 1000 Ohm load the output voltage is 18.0V.

AUDIBLE ALARM (Optional)

Function	Activated on High Alarm. (After High Alarm Delay)
Drive capability	24V @ 50 mA max. If greater drive is required, use a slave relay.
Silencer	Push-button silencer (auto-reset). Connection for remote silencer push-button (optional)
Time Delay	0 – 20 minutes Delay – On. (In addition to High Alarm Delay-On).

DIAGNOSTICS

<u>HARDWARE REV.</u> 1.0	<u>SOFTWARE REV.</u> N/A	Page 4 of 8
-----------------------------	-----------------------------	-------------

<u>MODEL</u> Enmet GAS-ALERT	<u>DOCUMENT TYPE</u> USER MANUAL	<u>DOCUMENT FILE NAME</u> mgsirt15.doc	<u>REV.</u> 1.5
<u>CREATE DATE</u> 08/25/97	<u>REV. DATE</u> 3/29/2004	<u>PRINT DATE</u> 3/29/2004	

Push to Test push-button. Tests by forcing a Sensor Fault on the internal sensor. Alarm lights, relays, and BAS status signals are tested. Note: the time delay settings are still active during test. Adjust them to 0 minutes prior to test if the time delays are not to be tested.

POWER

Internal sensor only	24 VDC @ 0.5A max. (Standard) or 115 VAC @ 0.15A max.
Remote Sensor System	24 VDC @ 0.5A + 0.25A per Remote Sensor or 115 VAC @ 0.15A + 0.1A per Remote Sensor

MECHANICAL SPECIFICATIONS

Enclosure	Nema 4X, Epoxy Coated Steel
Dimensions	8" X 8" X 5"
Weight	6.5 lb.

ENVIRONMENTAL SPECIFICATIONS

Operating Temp.	-20 to 60 Deg. C
Relative Humidity	90% max. with no condensation.

5.0 INSTALLATION

5.1 MECHANICAL INSTALLATION

See Drawing 972305

5.2 ELECTRICAL HOOKUP

See drawing 972300

5.2.1 POWER

The standard power input is 24 VDC. If this is being used then locate the power supply connector at the bottom left of the Gas-Alert board and connect the 24 VDC as shown on drawing 972300. The connector is a 2-conductor mating pair arrangement. The connector may be unplugged for ease of wiring.

If 115 VAC power is to be used then locate the separate 115 VAC input power supply and connect the Line, Neutral and GND connections as labeled on the back panel.

5.2.2 REMOTE SENSOR

The Gas-Alert may have one integral or remote sensor. The remote sensor is connected via a 4-strand 16-18 gauge shielded wire, cable that carries power (2 conductors) and a common remote signal pair.

Locate the Remote Sensor connector on the left edge of the Gas-Alert board. The connector is a 4-conductor mating pair arrangement. The connector may be unplugged for ease of wiring. See drawing 972300.

5.2.3 RELAYS

Three DPDT 250 VAC / 5A contact relays are provided: for High Alarm, Low Alarm, and Sensor Fault. These relays are common to the integral sensor and the remote sensors, i.e. if the integral sensor or the remote sensor is in low alarm then the Low Alarm relay and LED are activated.

Sensor Fault: If any sensor (integral or remote) is removed then the Sensor Fault relay and LED are activated.

NOTE: Each relay may be set as Fail-Safe (normally energized, and de-energized on alarm condition) or non-fail-safe (normally de-energized, and energized on alarm condition).

<u>HARDWARE REV.</u> 1.0	<u>SOFTWARE REV.</u> N/A	Page 5 of 8
-----------------------------	-----------------------------	-------------

MODEL Enmet GAS-ALERT	DOCUMENT TYPE USER MANUAL	DOCUMENT FILE NAME mgslrt15.doc	REV. 1.5
CREATE DATE 08/25/97	REV. DATE 3/29/2004	PRINT DATE 3/29/2004	

The connections are as shown on drawing 972300.

5.2.4 BUILDING AUTOMATION SYSTEM (BAS) CONNECTION

The Gas-Alert provides external High and Low Alarm status signals (+24V when in alarm, 0 V when not) for connection to a Building Automation System (BAS). The signals are non isolated and are referenced to the provided +24V power supply ground.

The connection is located on the right edge of the Gas-Alert board as shown on drawing 972300.

5.2.5 AUDIBLE ALARM (Optional)

The Audible Alarm connector (2 conductor) is located on the right edge of the Gas-Alert board. The connection is either to a Horn / Buzzer on the side panel (typical) OR connected to a remote horn / buzzer (both optional). The output is +24V @ 50 mA (maximum current). Some horns / buzzers are polarity sensitive i.e. make sure the + output is connected to the + terminal of the horn.

6.0 CALIBRATION AND SETUP

6.1 CALIBRATION

The Gas-Alert has one sensor system either remote or integral.

6.2.1 CALIBRATING THE INTEGRAL SENSOR

NOTE: If an integral sensor is not being used a resistor is factory jumpered across the input terminal block (J9). Verify this is in place and proceed to 6.2.2

Calibrating the integral sensor requires:

- Enmet Calibration Kit which should have calibration gas concentrations for the required High and Low alarm values.
 - Small slot screwdriver to adjust the alarm levels.
 - The Gas-Alert should be powered up for 48 hours prior to calibration to allow the sensor to stabilize.
 - A Voltmeter.
1. Locate Test Point 1 (named TP1: Black) (See drawing 972300). It is located at the bottom left of the Gas-Alert board. Locate Test Point 2 (named TP2: Red). It is located roughly an inch above TP1. Plug the negative lead of the voltmeter into TP1 and the positive lead to TP2. The measured voltage will be in the 1.5 – 5 Volt range.
 2. Locate the Range potentiometer (labeled N) on the top edge of the Gas-Alert board. With the small adjusting screw, adjust the pot. to get approx. 2.8 volts on the voltmeter in clean air.
 3. Prior to calibration, adjust all 4 time delay pots to 0: fully counter clockwise. The delay adjust pots are in a group of 4 located on the top left edge of the Gas-Alert board.
 4. **SETTING THE LOW ALARM:** Setup the Enmet calibration kit as per the Enmet calibration kit drawing (see fig 1.0): You will need a gas canister containing the gas concentration of the low alarm level i.e. if the low alarm is to be set at 35 ppm Carbon Monoxide then the canister should contain 35 ppm Carbon Monoxide. Attach the calibration cup over the Gas-Alert integral sensor and adjust the gas flowrate to about 0.75 – 1 SCFH. Note: the use of the voltmeter is optional, but is useful to determine the length of the calibration time. The sensor requires roughly 1 to 2 minutes to stabilize or until the voltage drop stabilizes.
 5. Locate the Low Alarm adjustment pot. labeled “L” in drawing 972300. It is located on the top edge of the Gas-Alert board.
 6. Also locate the Low Alarm indicator LED (Yellow) which is below the adjustment pots. After the

HARDWARE REV. 1.0	SOFTWARE REV. N/A	Page 6 of 8
-----------------------------	-----------------------------	-------------

<u>MODEL</u> Enmet GAS-ALERT	<u>DOCUMENT TYPE</u> USER MANUAL	<u>DOCUMENT FILE NAME</u> mgslrt15.doc	<u>REV.</u> 1.5
<u>CREATE DATE</u> 08/25/97	<u>REV. DATE</u> 3/29/2004	<u>PRINT DATE</u> 3/29/2004	

sensor has stabilized, if the Low Alarm LED is already lit then adjust the Low Alarm pot. clockwise until the alarm LED just goes off then adjust it counterclockwise until the LED just comes on, plus 10 degrees. If the LED is already off, adjust the pot. counterclockwise until the LED just goes on, plus 10 degrees.

- Repeat steps 4 – 6 for the High Alarm using the high level calibration gas, but in this case, use the pot. marked “H” to adjust the alarm, and the leftmost RED LED for the High Alarm indication. See 6.2.3.

6.2.2 CALIBRATING THE REMOTE SENSOR

The Remote Sensor requires individual calibration. This has integral alarms and sensor fault indicators (total 4). The Remote Sensor outputs a signal on the common Vsig wire (one of the 4 in the connection cable) to indicate its alarm level.

Calibrating the remote sensor requires:

- Enmet Calibration Kit which should have calibration gas concentrations for the required High and Low alarm values.
 - Small slot screwdriver to adjust the alarm levels.
 - The sensor should be powered up for 48 hours prior to calibration to allow the sensor to stabilize.
 - A Voltmeter.
1. Locate Test Point 1 (named TP1: Black) (See drawing 93005500). It is located at the bottom right of the remote sensor board. Locate Test Point 4 (named TP4: Red). It is located at bottom left of the remote sensor board. Plug the negative lead of the voltmeter into TP1 and the positive lead to TP5. The measured voltage will be in the 1.5 – 5.0 Volt range.
 2. Locate the Range potentiometer (labeled “N”) on the Remote Sensor board. It is the bottom-most of the group of 3 pots (See drawing 93005500 for pot. labeled “N”). Adjust the pot. to get approx. 2.8 volts on the voltmeter in clean air.
 3. SETTING THE LOW ALARM: Setup the Enmet calibration see Fig. 1.0: You will need a gas canister containing the gas concentration of the low alarm level i.e. if the low alarm is to be set at 35 ppm then the canister should contain 35 ppm. Attach the calibration cup over the sensor and adjust the gas flowrate to about 0.75 – 1 SCFH. Note: the use of the voltmeter is optional, but is useful to determine the length of the calibration time. The sensor requires roughly 1 to 2 minutes to stabilize or until the voltage drop has stabilized.
 4. Locate the Low Alarm adjustment pot. labeled “L” (see drawing 93005500).
 5. Also locate the Low Alarm indicator LED (Yellow) which is to the left of adjustment pots. If the Low Alarm LED is already lit then adjust the Low Alarm pot. clockwise until the alarm LED just goes off and then adjust counterclockwise until the LED comes back on plus about 10 degrees. If the LED is already off, adjust the pot counterclockwise until the LED just goes on plus about 10 degrees.
 6. Repeat steps 3 – 5 for the High Alarm, using the high level calibration gas, but in this case, use the pot. marked “H” to adjust the alarm, and the RED LED closest to the yellow LED for the High Alarm indication.

<u>MODEL</u> Enmet GAS-ALERT	<u>DOCUMENT TYPE</u> USER MANUAL	<u>DOCUMENT FILE NAME</u> mgsirt15.doc	<u>REV.</u> 1.5
<u>CREATE DATE</u> 08/25/97	<u>REV. DATE</u> 3/29/2004	<u>PRINT DATE</u> 3/29/2004	

THE COMPONENTS IN YOUR KIT

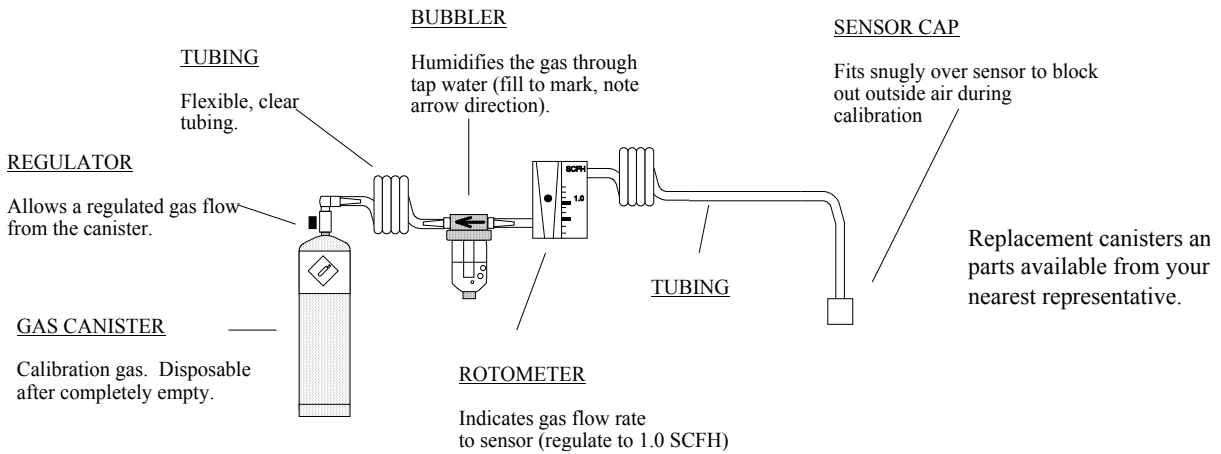

Figure 1.0

6.2.3 SETTING THE TIME DELAY RELAYS

1. **SETTING THE ALARM DELAYS:** The High Alarm Delay-On is the leftmost pot. on the top edge of the Gas Alert board, while the Delay-Off is the 2nd from the left. On delay means relay state will change after “X” minutes after concentration level reaches. Off delay means relay state will stay on “X” minutes after concentration levels are back to normal. Locate the Low Alarm delay pots which are on the top edge of the Gas-Alert board and are the 3rd and 4th pots from the left edge. See drawing 972300 for placement. The Delay-On is the leftmost of the group of 2 (3rd from the left edge). Adjust the pots for the desired time delays. Full scale is about 20 minutes so half way is about 10 minutes. This concludes the Low Alarm setup.
2. **TIP:** Setting the delay “ON” for a few minutes will allow the unit to ignore spurious alarms caused by sudden clouds of gas momentarily passing over the sensor. Setting the delay “OFF” for a determined time will keep the fans operating after the sensor has cleared to ensure remote areas from the sensor are also clear.
3. **SETTING THE HORN DELAY:** The audible alarm (optional) is triggered by the High Alarm. The audible alarm delay is therefore in addition to the High Alarm delay. The sequence is as follows: when the gas concentration is higher than the high alarm setpoint for at least the high alarm Delay-On then the high alarm relay and indicator (RED) are activated. At this time the audible alarm is also triggered. After an additional time as set by the horn delay, the audible alarm is turned on and continues until either the High alarm is deactivated or the silencer switch (Board mounted) is pressed. The horn time delay also has a 0-20 minute scale. The horn may thus be turned on a maximum of about 40 minutes after the sensor senses a high alarm (High Alarm Delay-On plus the Horn Delay-On).

6.2.4 COMPLETION

Replace the cover on the sensor and control box. Remove the flow gauge from the calibration gas. Calibration is complete.

REFRIGERANT LEAK DETECTION
AND
CHILLER ALARM MASTER PANEL

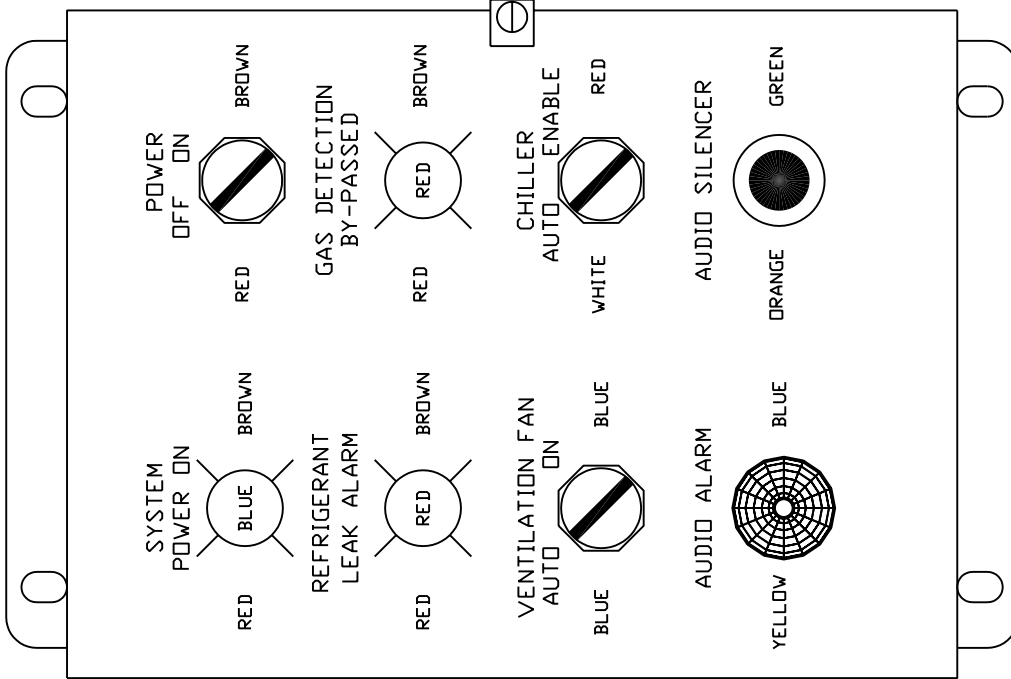

ENCLOSURE COVER - NEMA 12

NOTES:

ALL DIMENSIONS ARE IN INCHES
FOR TBI CONNECTIONS REFER TO DWG. 983401
ENCLOSURE IS A EUROBEX 5412 ESCH 14126 (14H X 12W X 6DEEP)
MOUNTING DIMENSIONS ARE 14.65 VERTICAL & 10 1/16 HORIZONTAL
MOUNTING HOLES ARE OBLONG 0.250 X 0.500

ENCLOSURE SUBPLATE

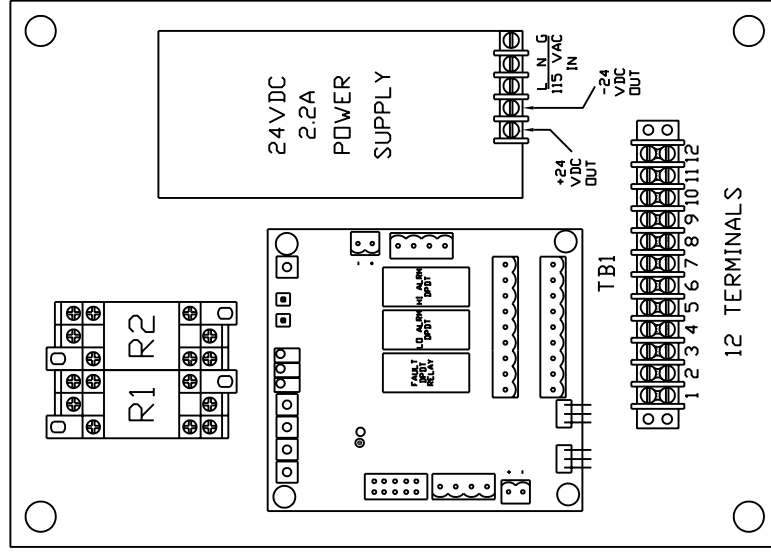

1	04/20/99	CHANGE OF BOX SIZE	CHKD	APPD
REV	DATE	DESCRIPTION	CHKD	APPD
REVISIONS				
ENMET CANADA LTD.		PROJECT: YORK APPLIED SYSTEMS		
DWG. STATUS	BY	DATE	TITLE	
DRAWN	C.M.P.	16 11 98	COVER AND SUBPLATE	
CHECKED			LAYOUT DRAWING	
APPROVED				
SCALE	REF. NOS.	YORK STANDARD	DWG. NO.	REV.
N.T.S.			983405	1 1

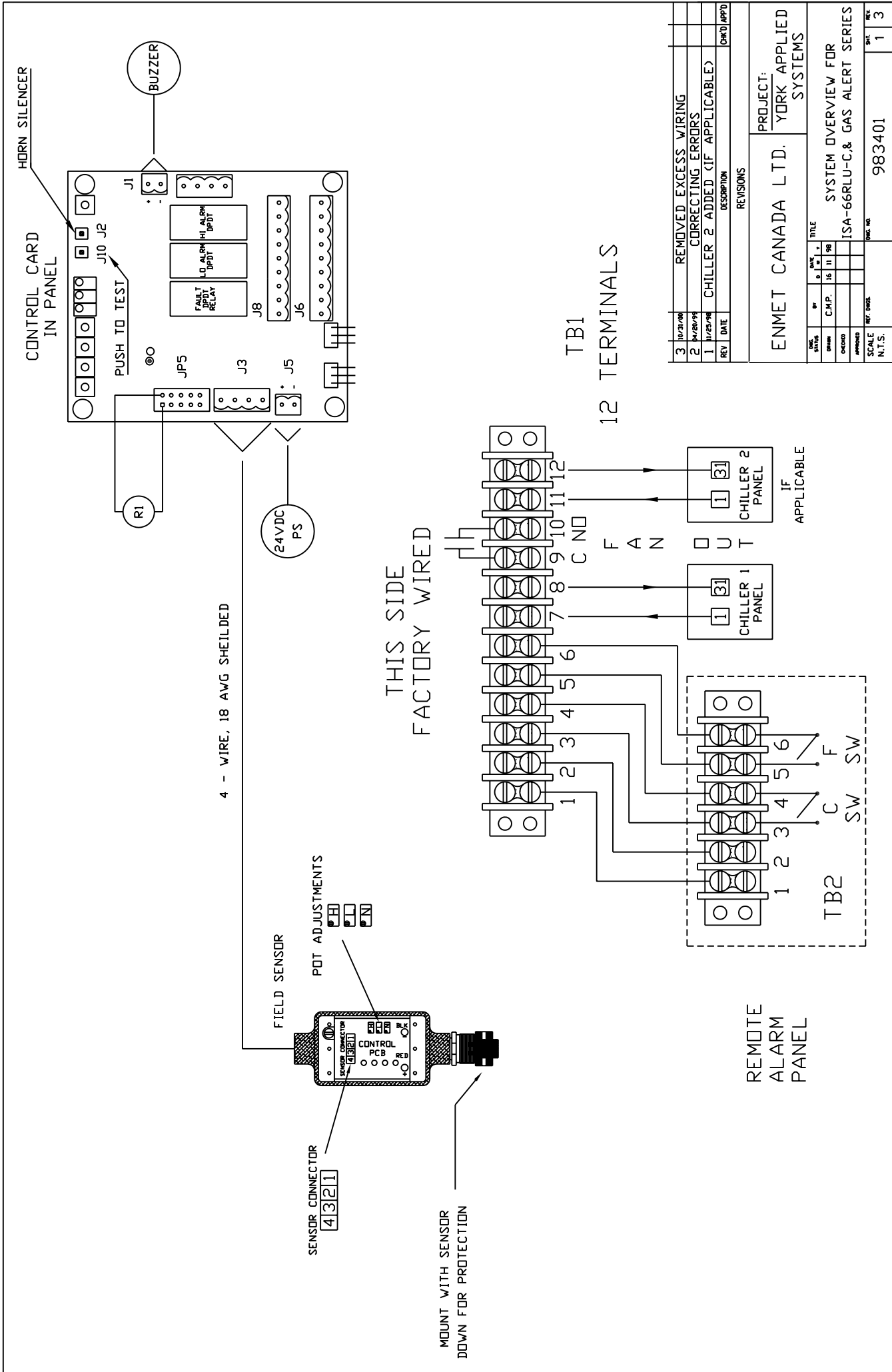

HORN SILENCER

BUZZER

CONTROL CARD
IN PANEL

PUSH TO TEST

4 - WIRE, 18 AWG SHIELDED

FIELD SENSOR

SENSOR CONNECTOR
4 3 2 1

POT ADJUSTMENTS

MOUNT WITH SENSOR
DOWN FOR PROTECTION

THIS SIDE
FACTORY WIRED

TBI
12 TERMINALS

REMOTE
ALARM
PANEL

3	10/21/90	REMOVED EXCESS WIRING		
2	04/28/90	CORRECTING ERRORS		
1	11/25/88	CHILLER 2 ADDED (IF APPLICABLE)		
REV	DATE	DESCRIPTION	CHK'D	APP'D
REVISIONS				
ENMET CANADA LTD.		PROJECT: YORK APPLIED SYSTEMS		
DATE	BY	DATE	TITLE	
	DRM	C.M.P.	16	11
DESIGNED			SYSTEM OVERVIEW FOR	
APPROVED			ISA-66RLU-C & GAS ALERT SERIES	
SCALE	REF. DWG.	DWG. NO.	983401	REV.
N.T.S.				1

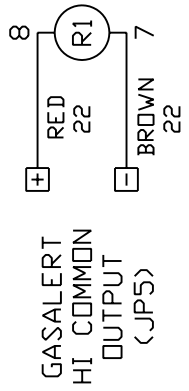
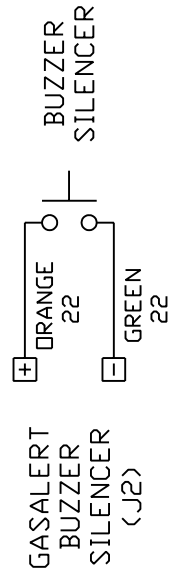
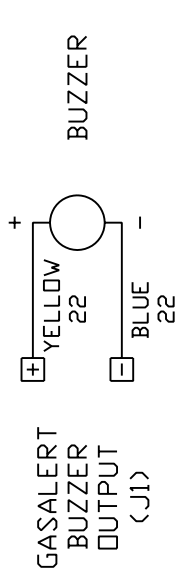
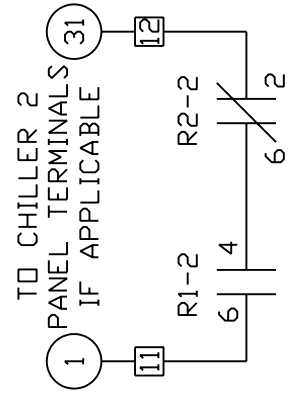
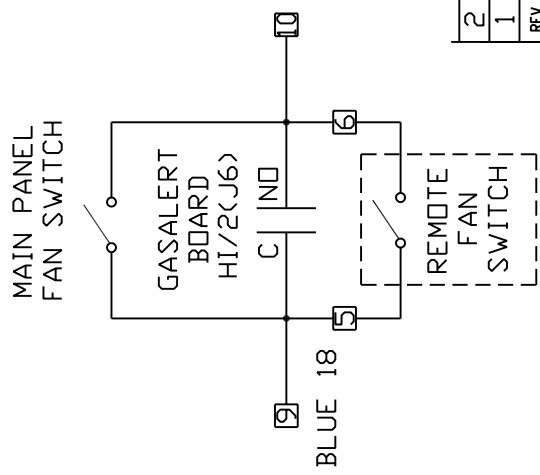
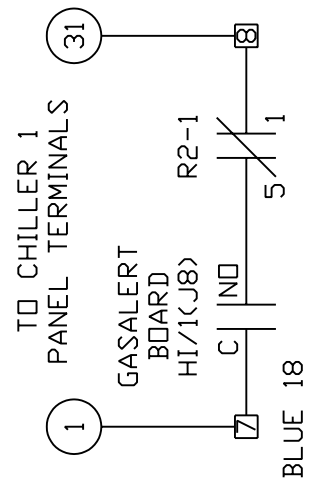
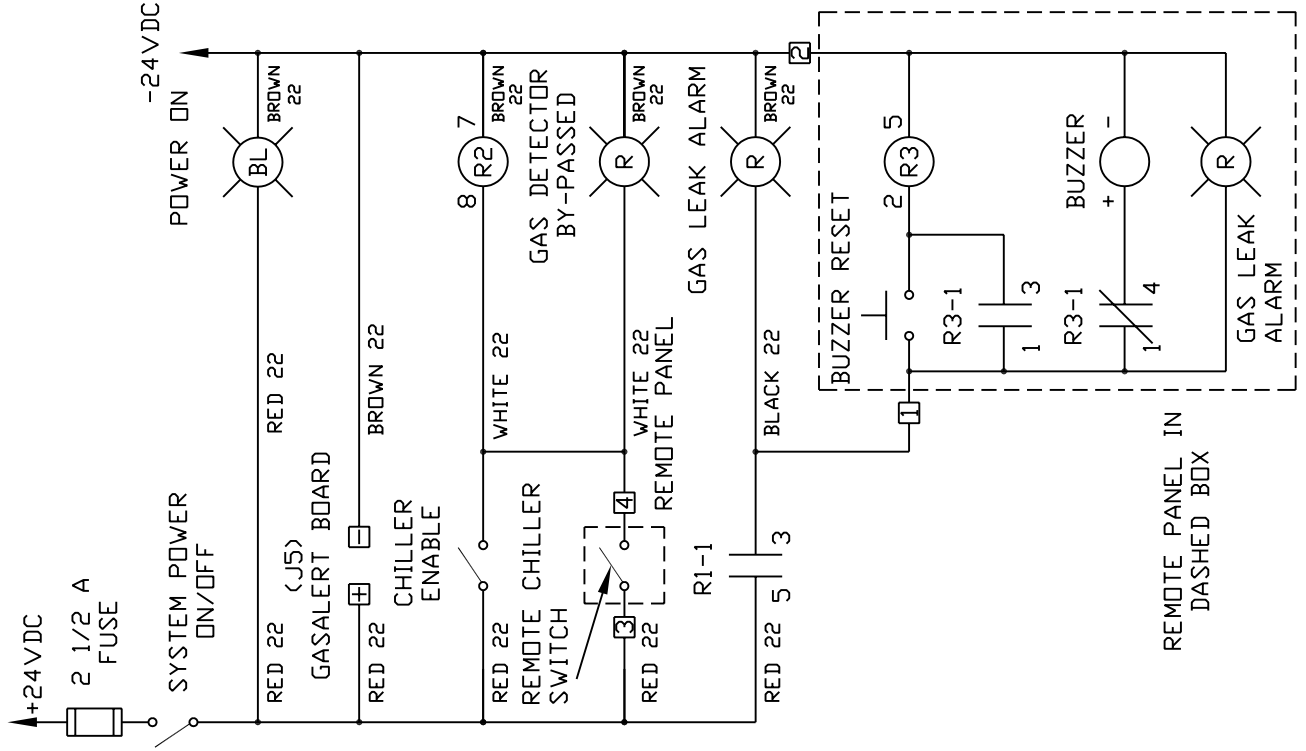

NOTE:
IF ADDITIONAL CHILLER IS USED THEN AN EXTRA CONTACT FROM R1 AND R2 WOULD HAVE TO BE USED. ANY MORE THAN TWO CHILLERS WOULD REQUIRE 4 POLE SLAVE RELAYS.

REV	DATE	DESCRIPTION	CHK'D	APP'D
2	01/27/99	R2 NOW R3, ADDED 2.5A FUSE		
1	11/25/98	CHILLER 1 & 2 TERMINALS ADDED		

REVISIONS

PROJECT: _____

ENMET CANADA LTD.

DWG. STATUS	BY	DATE	TITLE
DRAWN	C.M.P.	16 11 98	LADDER LOGIC FOR YORK PANEL
CHECKED			
APPROVED			

SCALE N.T.S. REF. DWGS. YORK STANDARD

DWG. NO. 983402

SHT. 1

REV. 2

SENSOR VOLTAGE TEST POINTS

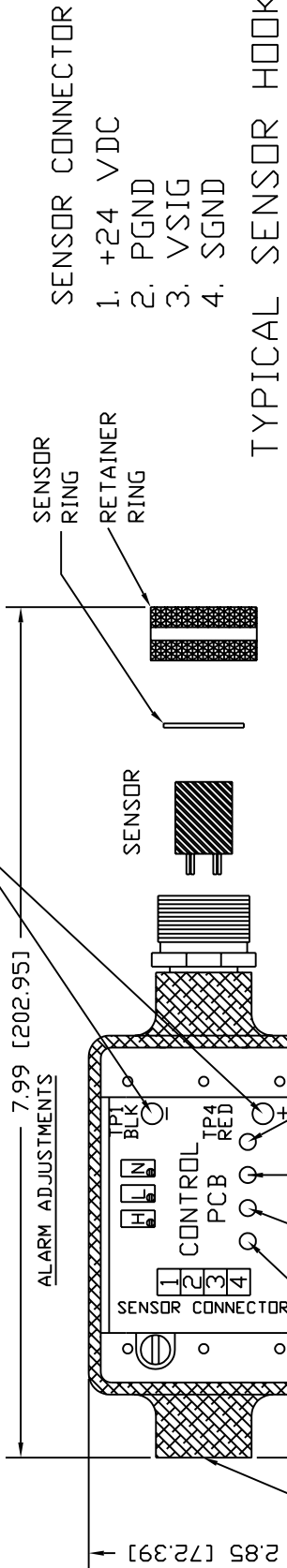

TYPICAL SENSOR HOOKUP

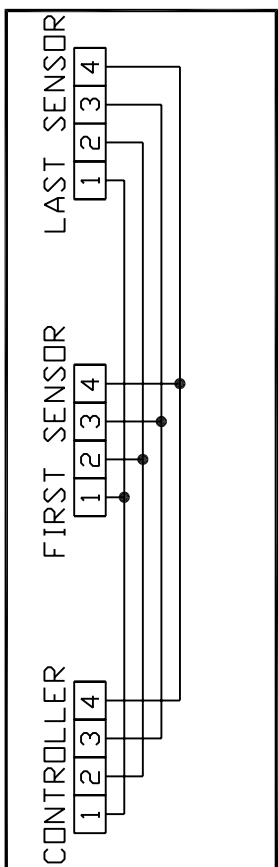

CALIBRATIONS

HIGH _____ PPM
 LOW _____ PPM
 REFRIGERANT _____

INCHES [mm]

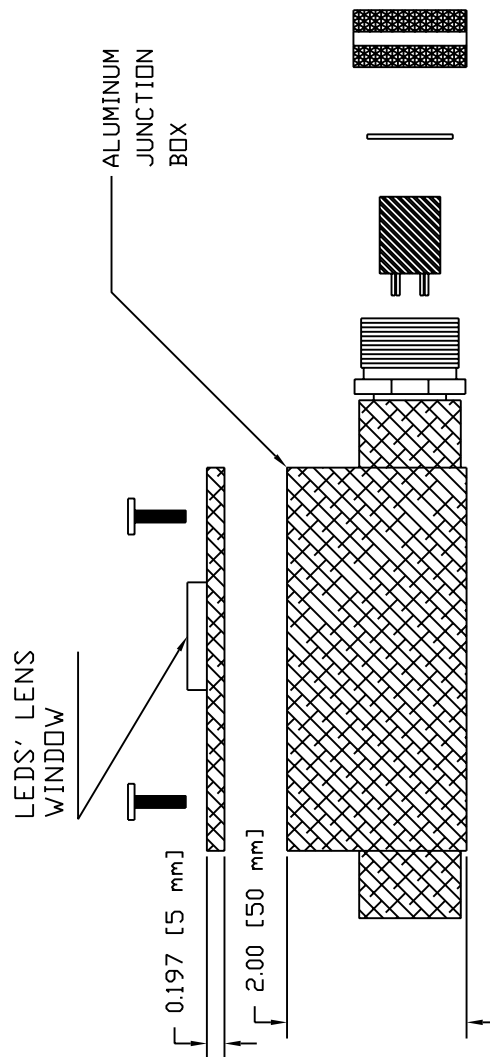

REV	DATE	DESCRIPTION	CHK'D	APP'D
4	1/10/00	CHANGED TP2 TO TP4 & TP3 TO TP1		
3	4/14/97	ADDED TP2 & TP3 TEST POINTS		
2	9/24/96	CLARIFIED ALARM ADJUSTMENTS		
1	8/19/94	SENSOR CONNECTOR TERMINATIONS CHANGED		
1	8/19/94	R,Y&G POT. MARKINGS CHANGED TO H,L&N RESP.		

REVISIONS

PROJECT: ENMET CANADA LTD.

DMC STATUS	BY	DATE	TITLE
DRAWN	C.P.	18 11 93	REMOTE SENSOR ASSEMBLY
CHECKED			
APPROVED			

SCALE: N.T.S. REF. NOS. _____ DMC. NO. 93005500 REV. 1 4