

ENMET Corporation
PO Box 979
Ann Arbor, MI 48106-0979

TX2000 / OX2000
Operation and Maintenance
Manual

80006-016
August 1999
MCN-326, 08/04/00
MCN-251, 04/13/01
MCN-266, 09/25/01

Table of Contents

1.0 Introduction	1
1.1 Unpack.....	1
1.2 Check Order.....	1
1.3 Serial Numbers	1
2.0 Features	2
2.1 Features.....	2
2.2 Power Supply	4
2.3 Sensor.....	5
2.3.1 Replacement of Sensor.....	5
3.0 Operation	6
3.1 Turn On the Instrument.....	6
3.2 Turn Off the Instrument.....	6
3.3 Backlight	6
3.4 Scrolling the Parameters	7
3.5 Alarms	8
3.5.1 Gas Alarm.....	8
3.5.2 Fault Alarm.....	8
3.5.3 Clearing the Gas Alarm.....	9
3.5.3 Clearing the Fault Alarm.....	9
4.0 Maintenance	10
4.1 Use of the program:	10
4.2 Programming Menu.....	11
4.2 Calibration.....	12
4.2.1 Adjusting the zero in clean air (for TX2000 version).....	12
4.2.2 Adjusting the sensitivity (TX2000 and OX2000).....	13
4.3 Sensor Replacement	14
5.0 WARRANTY.....	15

List of Illustrations

Figure 1: Exterior View of TX2000 / OX2000.....	3
Figure 2: Interior View TX2000 / OX2000.....	4
Figure 3: Sensor.....	5
Table 1: “Pulsed” Audio and Visual Alarms	8
Table 2: “Continuous” Visual and Audio Alarms	9
Figure 4: Entrance to Maintenance Menu Flow Chart	10
Table 3: Data for Oxygen and Toxic Sensors.....	14

1.0 Introduction

The **TX2000/OX2000** is a stand-alone, “pocket” oxygenometer or toximeter intended for the (continuous) detection of toxic or oxygen gases or vapors.

- It can be used in groups I or IIC explosive atmospheres, when equipped with approved batteries.
- The **TX2000/OX2000** is equipped with a plug-in sensor that can be accessed after unscrewing the sensor cap on the top of the instrument.
- It is powered by 3 x 1.5V batteries.
- The **TX2000/OX2000** displays the gas concentrations on a liquid crystal display fitted with a backlight.
- In case of an alarm or anomalies, the instrument activates an audio and visible alarm.
- The **TX2000** version has 2 alarm thresholds: the first can be adjusted by the user and the second is preset at the factory.
- The **OX2000** version has one abundance and deficiency threshold.
- The instruments have switches for turning the it on or off, for backlighting the display, for programming the alarm threshold etc...
- A periodic audio "BEEP" (factory-programmed intervals) shows that the instrument is working properly or indicates that the **TX / OX 2000** has been switched off deliberately. This “beep” can be disabled.

NOTE: *All specifications stated in this manual may change without notice.*

1.1 Unpack

Unpack the **TX/OX 2000** and examine it for shipping damage. If such damage is observed, notify both **ENMET** customer service personnel and the commercial carrier involved immediately.

Regarding Damaged Shipments

NOTE: It is your responsibility to follow these instructions. If they are not followed, the carrier will not honor any claims for damage.

- This shipment was carefully inspected, verified and properly packaged at our company and delivered to the carrier in good condition.
- When it was picked up by the carrier at **ENMET**, it legally became your company’s property.
- If your shipment arrives damaged:
 - Keep the items, packing material, and carton “As Is.” Within 5 days of receipt, notify the carrier’s local office and request immediate inspection of the carton and the contents.
 - After the inspection and after you have received written acknowledgment of the damage from the carrier, contact **ENMET** Customer Service for return authorization and further instructions. Have your Purchase Order and Sales Order numbers available.
- ENMET** either repairs or replaces damaged equipment and invoices the carrier to the extent of the liability coverage, usually \$100.00. Repair or replacement charges above that value are your company’s responsibility.
- The shipping company may offer optional insurance coverage. **ENMET** only insures shipments with the shipping company when asked to do so in writing by our customer. If you need your shipments insured, please forward a written request to **ENMET** Customer Service.

Regarding Shortages

If there are any shortages or questions regarding this shipment, please notify **ENMET** Customer Service within 5 days of receipt at the following address:

ENMET Corporation
 680 Fairfield Court
 Ann Arbor, MI 48108
 734-761-1270 734-761-3220 Fax

1.2 Check Order

Check, the contents of the shipment against the purchase order. Verify that the **TX2000/OX2000** is received as ordered. If there are accessories on the order, ascertain that they are present. Check the contents of calibration kits. Notify **ENMET** customer service personnel of any discrepancy immediately.





1.3 Serial Numbers

Each **TX2000/OX2000** is serialized. These numbers are on tags on the equipment and are on record in an **ENMET** database.

2.0 Features

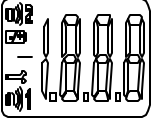
2.1 Features

See Figure 1

Feature	Description
Display 	<p>The liquid Crystal display allows messages to be read clearly:</p> <ul style="list-style-type: none"> • 3 digits 1/2 for displaying the measurement (0 to 1999 ppm or 0 to 30.0% O₂). • Equipped with back light by light-emitting diodes. • 4 pictograms supplementing the audio and visual alarms relating to the exceeding of thresholds, battery faults, maintenance mode.
ENTER Switch 	<ul style="list-style-type: none"> • Switching the instrument on or off • Enter
BACKLIGHT / Down Switch 	<ul style="list-style-type: none"> • Backlighting the display • Scrolling the parameters and menus • “down ” switch
ALARM / Up Switch 	<ul style="list-style-type: none"> • Turn off the gas alarm • “up” switch • "yes" or "no" for confirmation.
Visual Alarm	Red indicator clearly visible on 4 sides and located at the top of the instrument
Audio Alarm	Loud buzzer located on the front panel of the instrument
Sensor	<p>OX2000:Senses oxygen</p> <p>TX2000: Senses toxic gas</p> <ul style="list-style-type: none"> • See table 3 in section 4.3 for data on different sensors
Belt Clip	Clip to outside of clothing for hands-free operation

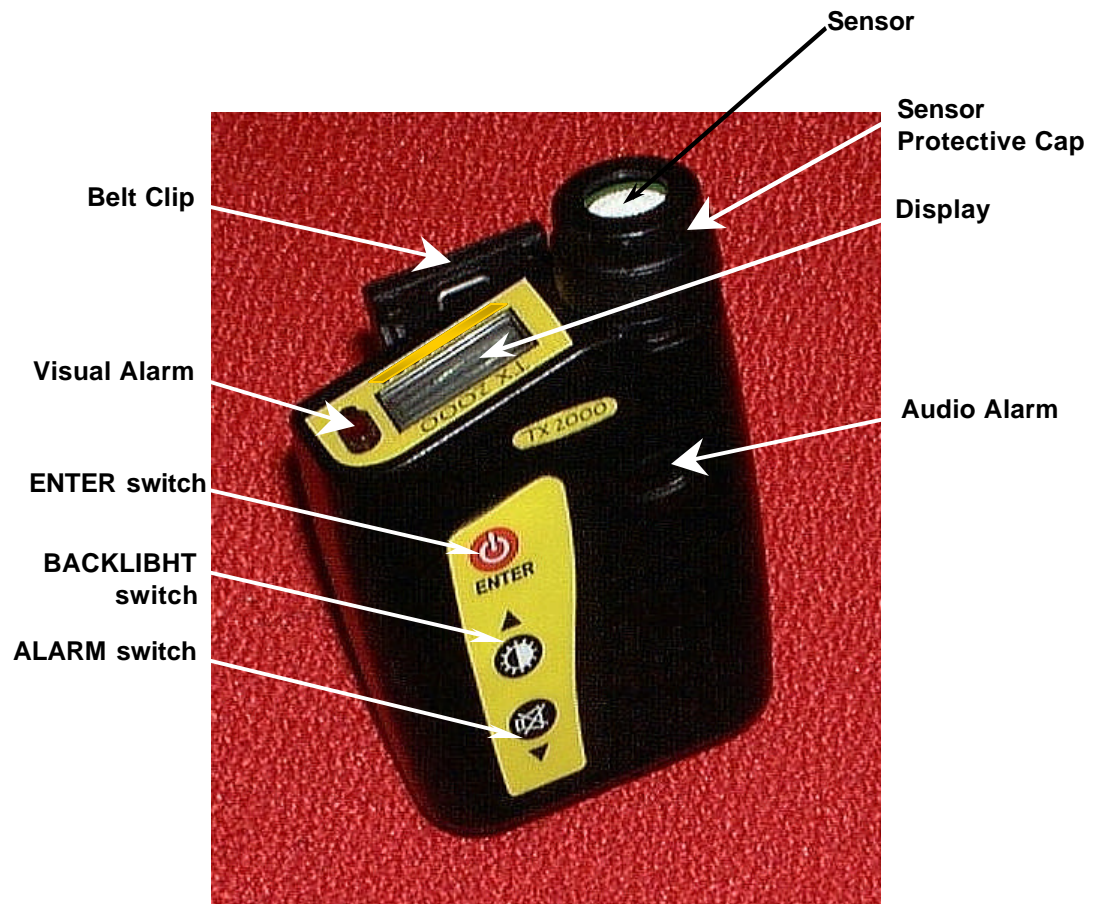

Figure 1: Exterior View of TX2000 / OX2000

2.2 Power Supply

It is provided by: **3 batteries LR01 1.5V** (DURACEL, ENERGIZER, PANASONIC).

WARNING: Do no change batteries in a hazardous area.

Under normal use conditions the instrument will run for 600 hours with batteries.

The instrument is certified for use in group I and II explosive atmospheres, when it is equipped with batteries of a type recommended by the manufacturer.

WARNING: Substitution of batteries or other components may compromise the intrinsic safety of the instrument.

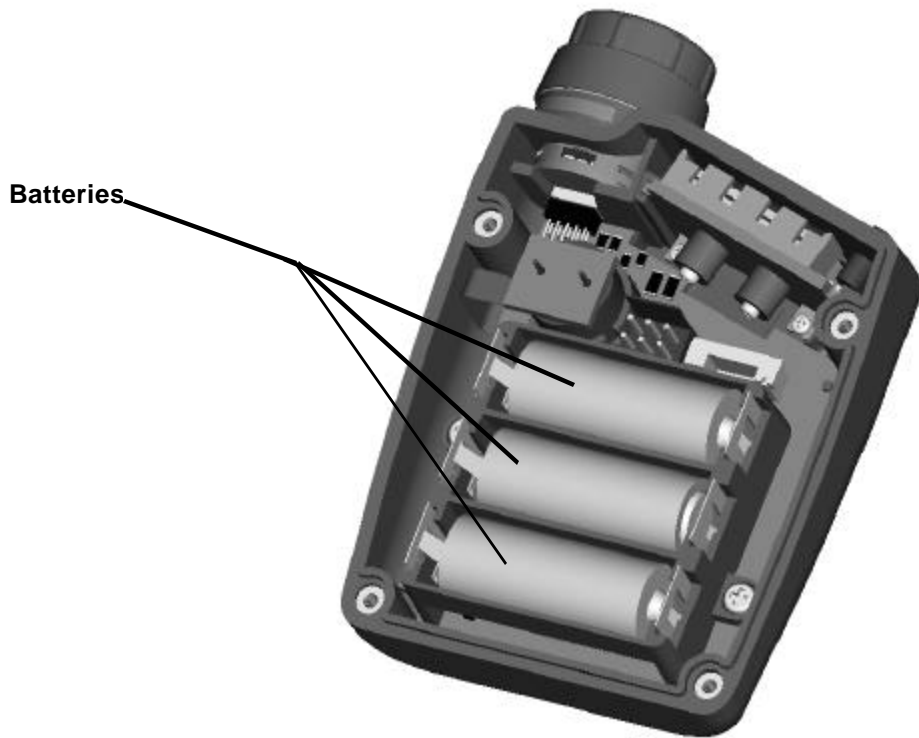

Figure 2: Interior View TX2000 / OX2000

2.3 Sensor

Being a vital element of the gas detector, the sensor of the **TX2000/OX2000** must be treated with care. Mechanical impacts, splashing with water etc... may impair the quality of the measurement or even, in extreme cases, destroy the sensors.

A water-repellent and anti-dust filter protects the top of the sensor.

Each sensor can detect one toxic or oxygen gas. See section 4.3, table 3 for data on sensors

2.3.1 Replacement of Sensor

The sensor is located on the top of the instrument. See figure 1.

The sensor can be removed once the protective cap is removed.

NOTE: The sensor must be inserted in the proper orientation. Align the tab on the bottom edge of the sensor with the groove in the instrument.

NOTE: In order to be able to operate correctly, the sensor should never be obstructed.

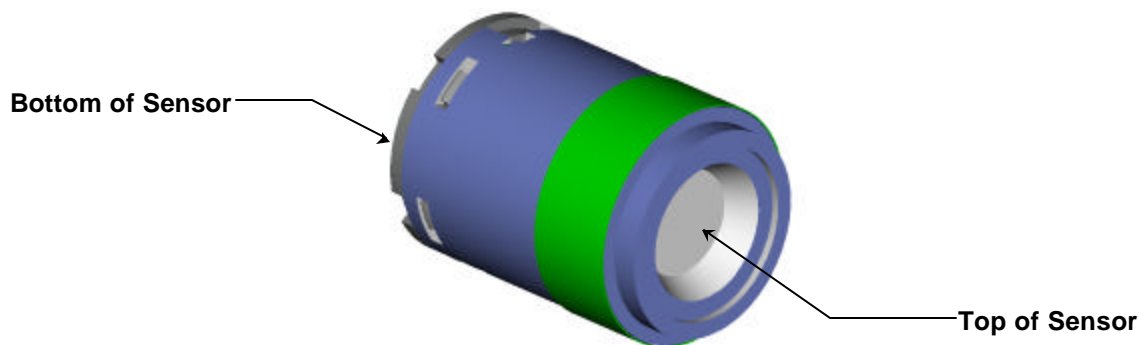

Figure 3: Sensor

3.0 Operation





3.1 Turn On the Instrument

The **TX/OX 2000** is turned on by pressing momentarily the **ENTER** switch

A regular audio “BEEP” signals that the instrument is operating correctly.

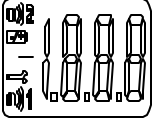
The interval between the "BEEPS" is factory-programmable, and the "BEEPS" can be disabled.

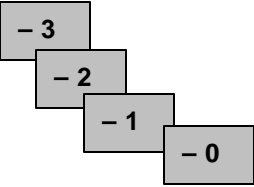
The following appear in succession on the display, accompanied by a continuous visual and audio signal:

	<p>Test display</p>
	<p>Software version used</p>
	<p>Automatic testing of the instrument on power-up, during countdown</p>
<p>Example:</p> 	<p>Display in ppm measurement for the toxic gas detected or in % for oxygen</p>

NOTE: The instrument is initialized to detect only **one type of gas (toxic or oxygen)**. The "detected" gas is programmed at the factory and the instrument is labeled with the type of gas. See section 4.3 table 3 for data of different sensors

3.2 Turn Off the Instrument

Press and hold the **ENTER** switch until instrument has counted down and turned off.

The display indicates the following countdown:

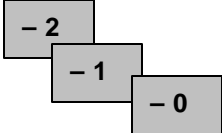
	<ul style="list-style-type: none"> • Press and hold the ENTER switch. • Displays 3-second countdown and turns off (with confirmation BEEP). • Then release the switch.
---	--







3.3 Backlight

In order to read the display in dark locations it is possible to illuminate the display by momentarily pressing the **BACKLIGHT** switch.

2 red LEDs placed on either side of the display provide this illumination for about 20 seconds.

3.4 Scrolling the Parameters

By pressing momentarily and successively on the BACKLIGHT switch.

Press BACKLIGHT Switch		With first press of switch, display is back-lighed then
Press BACKLIGHT Switch	 	The lowest measurement detected since the instrument was switched on (refreshed each time the instrument is switched back on) Cyclic display of measurement appears if no switch is pressed *
Press BACKLIGHT Switch	 	The highest measurement detected since the instrument was switched on (refreshed each time the instrument is switched back on) Cyclic display of measurement appears if no switch is pressed *
Press BACKLIGHT Switch		Display of segments indicate operating battery current voltage status Cyclic display of measurement appears if no switch is pressed *
Press BACKLIGHT Switch		Return to display of the current measurement in ppm of the toxic measurement detected or in % oxygen

* If no switch is pressed in 3 min., the instrument will return in normal display of current measurement.

3.5 Alarms

3.5.1 Gas Alarm

The “gas” audio and visual alarm is triggered when at least one of the two preprogrammed instantaneous thresholds is exceeded.

TX2000 Toxic Version

- **The adjustable threshold:** (threshold 1): can be altered by using the maintenance / programming mode. See section 4 for entrance to maintenance menus.
- **The fixed threshold:** (threshold n 2): programmed by **ENMET** when the instrument is initialized and cannot be altered by the user, the threshold is 60 % of scale.

OX2000 Oxygen Version

- **The abundance threshold:** adjustable up to 25% oxygen.
- **The deficiency threshold:** adjustable from 21% to 0% oxygen.

CAUTION: The **OX2000** thresholds are adjustable to exceed safe levels, 17% deficiency if adjusted beyond these levels, use instruments with caution. Failure to do so may result in **injury or death**.

When at least one of the two thresholds is exceeded, the TX2000 / OX2000 delivers a “pulsed” audio alarm and simultaneously the red visual alarm flashes.

An “alarm” pictogram flashes simultaneously under the current measurement value displayed.

Table 1: “Pulsed” Audio and Visual Alarms

Display	Cause	Remedy
XXPPM Alarm pictogram	Instantaneous threshold exceeded	Alarm can be cleared manually.
battery pictogram	The battery is beginning to discharge	Audio and visual alarms can be cleared Change batteries

3.5.2 Fault Alarm

The faults can be classed into 2 types:

- Those relating to the sensor (out-of-range, sensor worn out, unsuccessful calibration etc...).
- Those relating to the instrument itself: worn out batteries, **OX / TX2000** fault. They cause the following message to appear:



The various faults generate a “continuous” visual and audio alarm that cannot be cleared.

Table 2: "Continuous" Visual and Audio Alarms

Display	Cause	Result / Remedy
BAT Pictogram	<ul style="list-style-type: none"> The batteries are worn: The instrument is no longer usable. 	<ul style="list-style-type: none"> Alarm cannot be cleared. Switch off the instrument Replace batteries
OR	<ul style="list-style-type: none"> Measurement range exceeded. 	<ul style="list-style-type: none"> Alarm can be cleared manually. Acknowledge the alarm.
DEF 1	<ul style="list-style-type: none"> Zero fault: sensor zero shifted out of range 	<ul style="list-style-type: none"> Calibrate
DEF 2	<ul style="list-style-type: none"> Sensitivity fault 	<ul style="list-style-type: none"> Recalibrate, if the fault persists: the sensor must be replaced
DEF (cyclic) 128	<ul style="list-style-type: none"> Sensor not installed Incorrect sensor 	<ul style="list-style-type: none"> Alarm cannot be cleared Switch the instrument off Install sensor Replace with the correct type of sensor.
DEF (cyclic) 16	<ul style="list-style-type: none"> Measurement too negative or sensor faulty 	<ul style="list-style-type: none"> Recalibrate If the fault persists: the sensor must be replaced
DEF (cyclic) 4	<ul style="list-style-type: none"> Sensor worn out, low sensitivity 	<ul style="list-style-type: none"> Alarm cannot be cleared. Replace the sensor.
DEF (cyclic) 8	<ul style="list-style-type: none"> EEPROM fault: EEPROM memory is not initialized 	<ul style="list-style-type: none"> Return the instrument to ENMET to be reinitialized.
DEF 35 69	<ul style="list-style-type: none"> Communication problem between micro and EEPROM 	<ul style="list-style-type: none"> Return the instrument to ENMET for repair.
DEF to 64	<ul style="list-style-type: none"> Component fault: temperature detector is faulty 	<ul style="list-style-type: none"> Return the instrument to ENMET for repair.

3.5.3 Clearing the Gas Alarm

By pressing momentarily the ALARM button

Clearing the alarm involves canceling the "pulsed" audio signal and turning off the alarm indicator.

WARNING: If the alarm is cleared while a threshold is still exceeded the operator of the instrument must leave the dangerous area.

If the audio alarm is cleared while a threshold is still exceeded: the visual alarm will continue to flash and the corresponding pictogram will remain "steady".

The instrument will return to normal state when measurement is under the alarm threshold.

3.5.3 Clearing the Fault Alarm

In case of a fault, it is not possible to clear the "continuous" audio and visual alarms.

4.0 Maintenance

The operations and adjustments described in this section must be performed by authorized personnel, as they affect detection safety.

Important: Being a safety instrument, it is necessary to calibrate the **TX2000** or **OX2000** at least **twice a year**.

4.1 Use of the program:

Turn the instrument on. After the instrument stabilizes press **and hold for 5 seconds**, the BACKLIGHT and ENTER switches, **at the same time**. See figure 4 entrance to maintenance menu.

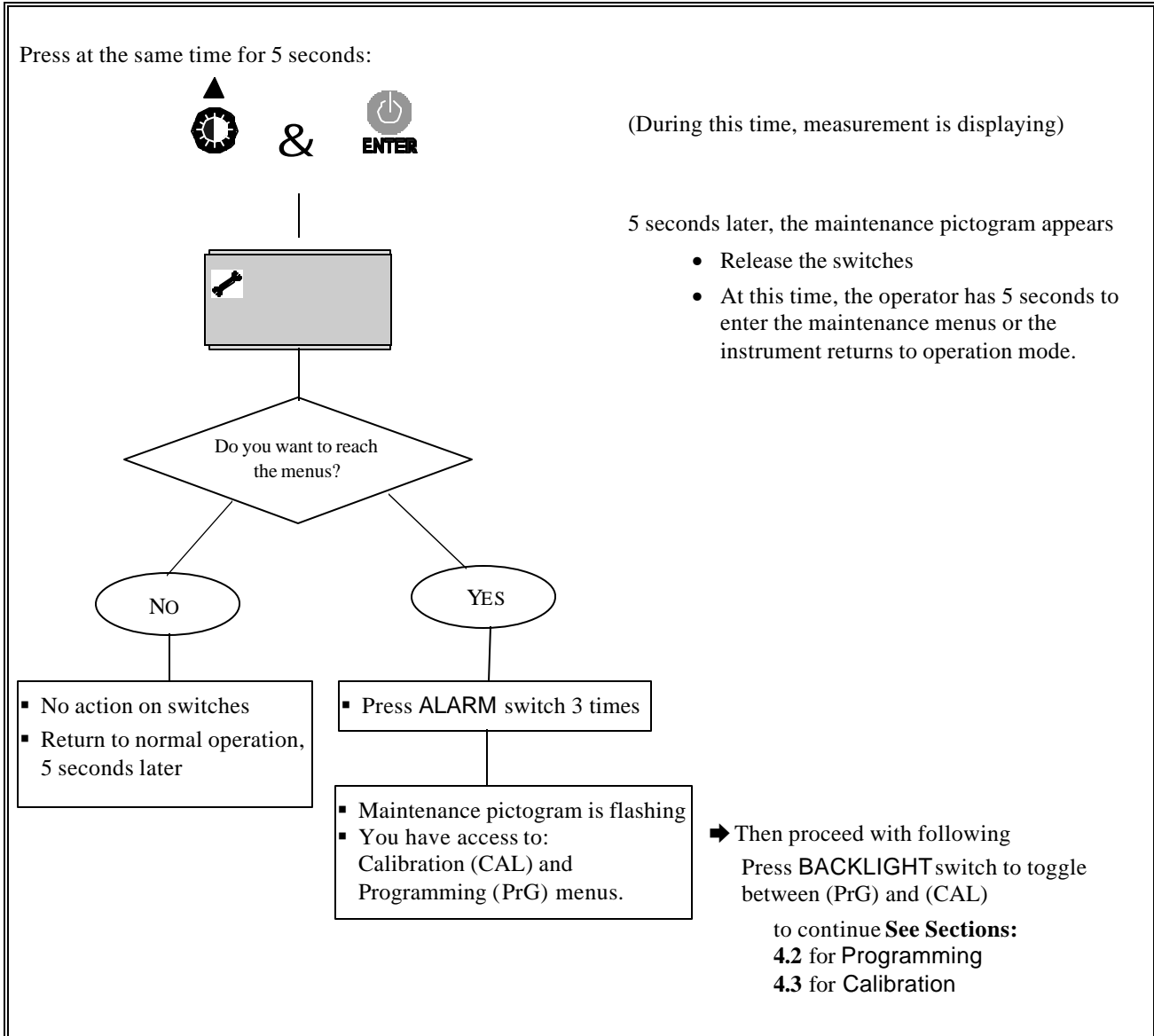







Figure 4: Entrance to Maintenance Menu Flow Chart

4.2 Programming Menu

See figure 4 for entrance to maintenance menu.

1. Press the ENTER switch at the programming display:		Enter the programming menu
2.		Display of the current alarm threshold
3. Press UP or DOWN switches:		To alter the alarm threshold
4. Press ENTER switch:		Enter the new threshold
5. Display:		Display "request for confirmation"
6. Press ENTER switch.		Display confirmation : NO
7. Press ALARM switch to toggle between yes and no:		Display confirmation : NO Display "yes or no" of confirmation (with each depression of the button) Display confirmation: YES
8. Press ENTER switch.		Enter the confirmation chosen <ul style="list-style-type: none"> In order to keep old programming, confirmation "NO" cancels changes.
9.		Return to the normal display of the current measurement

4.2 Calibration

Verify that the instrument is working properly by **calibration** performed with the help of a **calibration gas**. If the response is not adequate or when any of the following occur, perform a complete calibration.

Calibration must be done:

- ◆ At least every 6 months
- ◆ Whenever the instrument has been exposed to high concentrations of gas.
- ◆ When an instrument has been stored for more than one month without use.
- ◆ When changing of sensors.
- ◆ If “DEF16” fault appears (measurement too negative).



Within the calibration menu, "visible and audio" alarms are not triggered.

“Calibration” menu consists of:

- Setting the zero in clean air and the sensitivity with calibration gas.
- Adjust oxygen sensitivity in **OX2000** version.







4.2.1 Adjusting the zero in clean air (for TX2000 version)

See figure 4 for entrance to maintenance menu.

<p>1. Press the BACKLIGHT switch to toggle from programming to calibration menu:</p> <div style="display: flex; align-items: center; justify-content: center;"> <div style="border: 1px solid black; padding: 2px 5px; margin: 0 5px;">PrG</div> <div style="margin: 0 5px;">↔</div> <div style="border: 1px solid black; padding: 2px 5px; margin: 0 5px;">CAL</div> </div>	<p>Switch to display the calibration menu</p>
<p>2. Press ENTER switch:</p>	<p>Enter the calibration menu</p>
<p>3</p> <div style="border: 1px solid black; padding: 2px 5px; display: inline-block; margin: 5px 0;">- 0 -</div>	<p>Display : zero adjustment</p>
<p>4. Press ENTER switch:</p>	<p>To enter the zero adjustment procedure</p>
<p>5.</p> <div style="border: 1px solid black; width: 40px; height: 20px; margin: 5px auto;"></div>	<p>Display the current value "zero".</p>
<p>6. Press UP or DOWN switches:</p> <div style="display: flex; justify-content: space-around; align-items: center; margin-top: 10px;"> <div style="text-align: center;">  </div> <div style="text-align: center;">  </div> </div>	<p>To adjust value to “zero” if necessary</p>
<p>7. Press ENTER switch.</p>	<p>To enter the zero adjustment</p>

4.2.2 Adjusting the sensitivity (TX2000 and OX2000)

- Attach the calibration cover over the sensor.
- Connect the hose from the calibration kit and inject the calibration gas (>10% range of the gas detected otherwise only the zero will be confirmed), maintaining a flow rate of 30 l/h.
- In **OX2000** version, this adjustment can be done without gas but must be in clean air.
- Then continue scrolling the calibration menu: See sections 4.2.1

<p>1.</p> <div style="text-align: center;">  </div>	<p>Display the adjustment of sensitivity</p>
<p>2. Press ENTER switch:</p>	<p>To enter the sensitivity adjustment procedure</p>
<p>3.</p> <div style="text-align: center;">  </div> <p><i>Example:</i></p>	<p>The display indicates proper calibration gas. Apply the gas: ◆ Wait for the signal to stabilize.</p>
<p>4. Press UP or DOWN switches:</p> <div style="text-align: center;">  </div>	<p>To adjust calibration gas correct value</p>
<p>5. Press ENTER switch:</p>	<p>To enter the adjustment of sensitivity</p>
<p>6. Display:</p> <div style="text-align: center;">  </div>	<p>Display "request for confirmation"</p>
<p>6. Press ENTER switch.</p>	<p>Acceptance of request for confirmation</p>
<p>7. Press ALARM switch to toggle between yes and no:</p> <div style="text-align: center;">  </div>	<p>Display confirmation : NO Display "yes or no" of confirmation (with each depression of the button) Display confirmation: YES</p>
<p>8. Press ENTER switch.</p>	<p>Enter the confirmation chosen</p> <ul style="list-style-type: none"> ▪ NO: The measurements are not entered ▪ YES: The measurements are entered
<p>9.</p> <div style="text-align: center;">  </div>	<p>Return to normal display of current measurement</p>

NOTE: When the calibration procedure has been completed, do not forget to remove the calibration cap from instrument. Failure to do so will cause the instrument to be inaccurate.

4.3 Sensor Replacement

Necessary when:

- Instrument fails to calibrate, sensor is worn out (DEF4).
- Wrong type of sensor installed (DEF128).

NOTE: If other type of sensor is connected by mistake during sensor replacement, “DEF128” fault will be triggered.

Table 3: Data for Oxygen and Toxic Sensors

Gas / Unit of measure	Standard range	Accuracy (in % of full scale)	Resolution	Zero drift	Response time (in seconds)	Expected Life of Sensor (in months)	Warranty (in months)
CL2 ppm	10	< 5 %	0.1 ppm	< 0.5 ppm per 6 months	< 180	> 12	12
CO ppm	500	< 5 %	1 ppm	< 20 ppm per 6 months	< 45	24	12
H2 ppm	2000	< 5 %	1 ppm	< 50 ppm per 6 months	< 150	24	12
H2S ppm	100	< 5 %	1 ppm	< 1 ppm per 6 months	< 30	24	12
HCN ppm	30	< 5 %	0.1 ppm	< 0.5 ppm per 6 months	< 90	18	12
NH3 ppm	100	< 5 %	1 ppm	< 3 ppm per 6 months	< 220	> 12	9
NO ppm	100	< 5 %	1 ppm	< 2 ppm per 6 months	< 30	> 12	12
NO2 ppm	30	< 5 %	1 ppm	< 1 ppm per 6 months	< 100	> 12	12
O2 % by Volume	30	< 0.5 % volume O2	0.1% vol.	< 2% per month	< 20	> 12	12
O3 ppm	1	± 0.05 ppm	0.01 ppm	< 0.05 ppm per 6 months	< 120	12	12

5.0 WARRANTY

ENMET warrants new instruments to be free from defects in workmanship and material under normal use for a period of one year from date of shipment from **ENMET**. The warranty covers both parts and labor excluding instrument calibration and expendable parts such as calibration gas, filters, batteries, etc... Equipment believed to be defective should be returned to **ENMET** within the warranty period (transportation prepaid) for inspection. If the evaluation by **ENMET** confirms that the product is defective, it will be repaired or replaced at no charge, within the stated limitations, and returned prepaid to any location in the United States by the most economical means, e.g. Surface UPS/RPS. If an expedient means of transportation is requested during the warranty period, the customer is responsible for the difference between the most economical means and the expedient mode. **ENMET** shall not be liable for any loss or damage caused by the improper use of the product. The purchaser indemnifies and saves harmless the company with respect to any loss or damages that may arise through the use by the purchaser or others of this equipment.

This warranty is expressly given in lieu of all other warranties, either expressed or implied, including that of merchantability, and all other obligations or liabilities of **ENMET** which may arise in connection with this equipment. **ENMET** neither assumes nor authorizes any representative or other person to assume for it any obligation or liability other than that which is set forth herein.

NOTE: When returning an instrument to the factory for service:

- Be sure to include paperwork.
- A purchase order, return address and telephone number will assist in the expedient repair and return of your unit.
- Include any specific instructions.
- For warranty service, include date of purchase
- If you require an estimate, please contact **ENMET** Corporation.